

P/N 59611

NEVER EXCEED THE MANUFACTURERS MAXIMUM GROSS VEHICLE WEIGHT RATING.

DO NOT INSTALL THE AIR SPRING AS THE PRIMARY SUSPENSION SPRING. THIS PRODUCT IS INTENDED FOR LOAD ASSIST ONLY.

ALWAYS USE SAFETY STANDS, WEAR EYE PROTECTION, AND USE PROPER TOOLS WHEN INSTALLING THE RIDE CONTROL KIT.

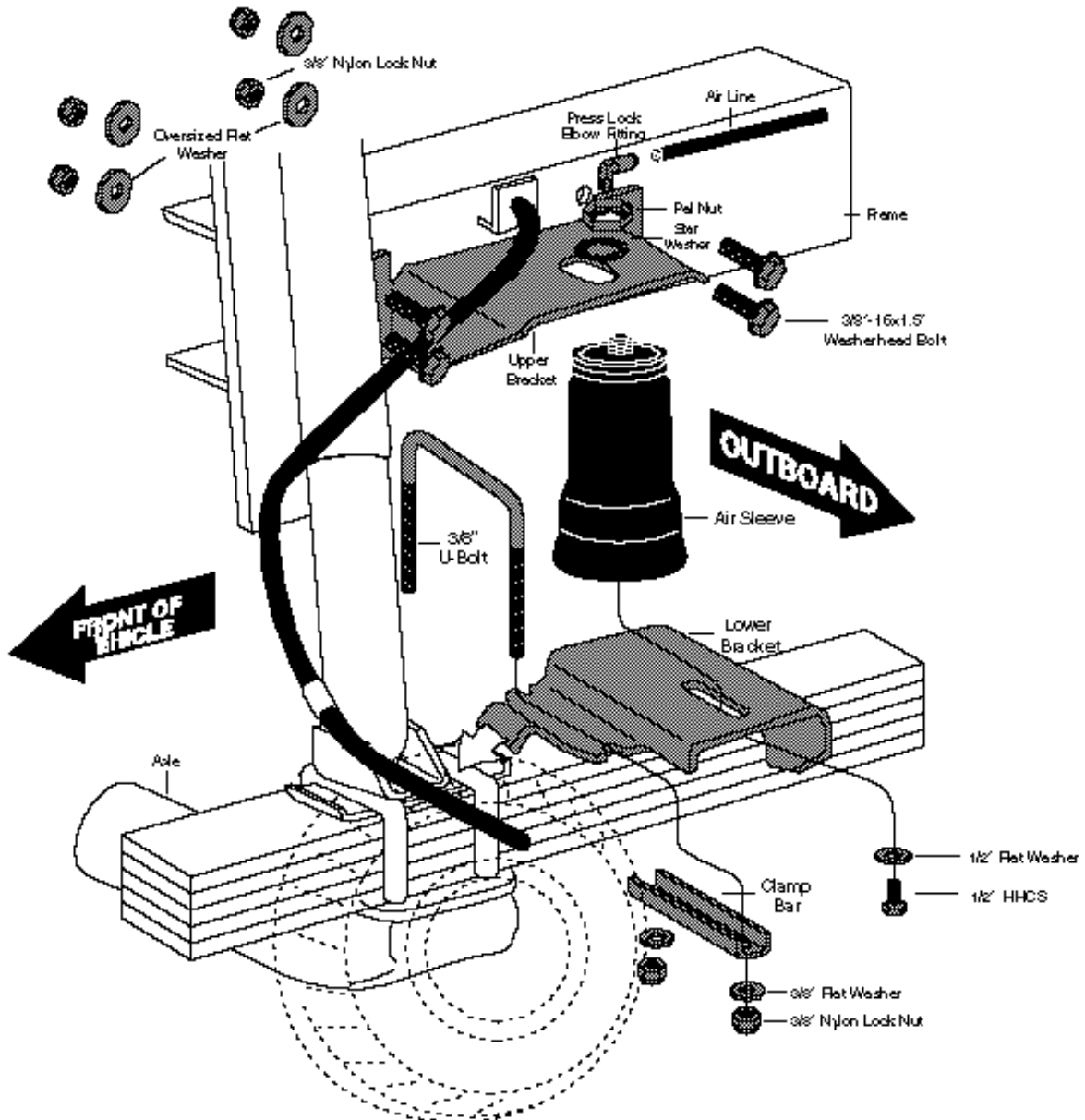

FIGURE 1

WARNING - DO NOT INFLATE ASSEMBLY WHEN IT IS UNRESTRICTED. ASSEMBLY MUST BE RESTRICTED BY SUSPENSION OR OTHER ADEQUATE STRUCTURE. DO NOT INFLATE BEYOND 100 P.S.I. IMPROPER USE OR OVER INFLATION MAY CAUSE ASSEMBLY TO BURST CAUSING PROPERTY DAMAGE OR SEVERE PERSONAL INJURY.

NORMAL RIDE HEIGHT: Normal ride height is defined as the measured distance from the bottom edge of the fenderwell to the center point of the wheel with the vehicle in the "as delivered condition" (without camper, tool boxes, unusual load, etc.). This measurement should be recorded for later reference. **All AIR LIFT kits are designed to be installed and operated at Normal Ride Height.**

1. Jack up front of vehicle or raise on hoist and remove front wheels. If there is a brake injunction block on the inside of the driver side frame rail, unbolt and pull valve out of the way. Save existing nuts for later use (Figure 5).
2. Attach top bracket to sleeve using star washer and nut, leave loose for later adjustment (Figure 1). LOOSELY attach the lower bracket to the bottom of the sleeve. Using the provided 1/2" flat washer and the 1/2" HHCS bolt (Figure 1). Note: Bottom brackets are left and right hand units. Slot faces outside of vehicle.

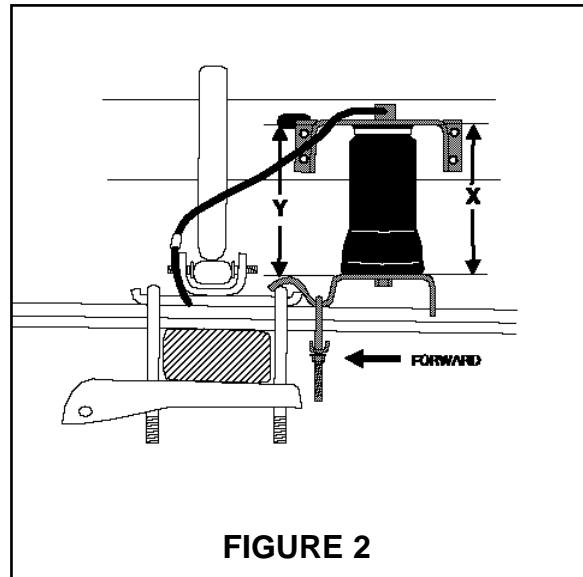

FIGURE 2

IMPORTANT -Your air springs will live much longer if they are not the suspension limiter in either compression or extension. The air spring compresses to 2.2" and extends to 10.5". Keeping the minimum required pressure or a pressure proportional to the load will prevent bottoming out. The shock absorber is usually the limiter on extension. If this is not the case, you should consider the use of limiting straps; especially if the vehicle is used off-road. The maximum inflated diameter of your air spring is 5.6". You must check to see that nothing is rubbing against the air spring within this diameter.

FAILURE TO MAINTAIN CORRECT MINIMUM PRESSURE (OR PRESSURE PROPORTIONAL TO THE LOAD), BOTTOMING OUT, OVER-EXTENSION, OR RUBBING AGAINST ANOTHER COMPONENT WILL VOID THE WARRANTY.

3. Set unit on the leaf spring with the tab of the lower bracket over the u-bolt (Figure 2). **THE LOWER BRACKET MUST BE OVER THE U-BOLT NOT THE SPRING RETAINER PLATE.** Attach to the leaf spring with u-bolt, clamp bar, flat washers, and locknuts, mount and tighten nuts to 20 ft.lbs (Figure 1).
4. Mount the upper bracket approximately 1/4" underneath the brake line bracket on the frame rail (Figure 3). Using the bracket as a template, mark two holes on each side of the bracket to be drilled. X and Y dimensions (Figure 2) should be equal. The sleeve should be mounted so that it follows the natural arc of the suspension through its full travel (Figure 1). Remove the upper bracket and drill your four 3/8" holes.

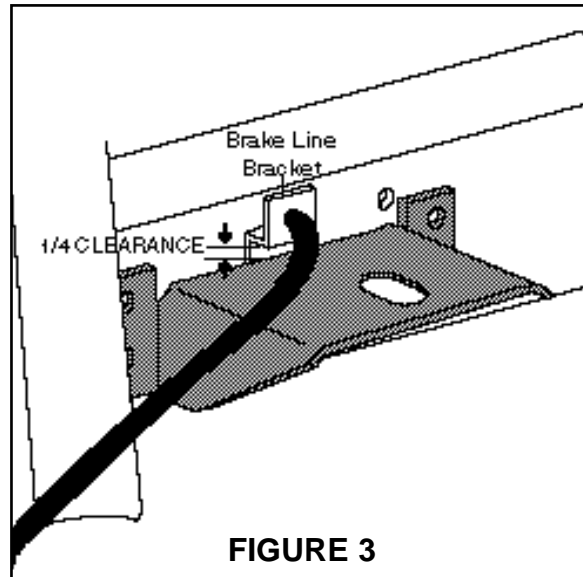

FIGURE 3

CAUTION: DO NOT DRILL HOLES INTO THE FRAME UNTIL ANY HYDRAULIC LINES, GAS LINE AND ELECTRICAL WIRES HAVE BEEN MOVED ASIDE ON BOTH SIDES OF FRAME RAIL.

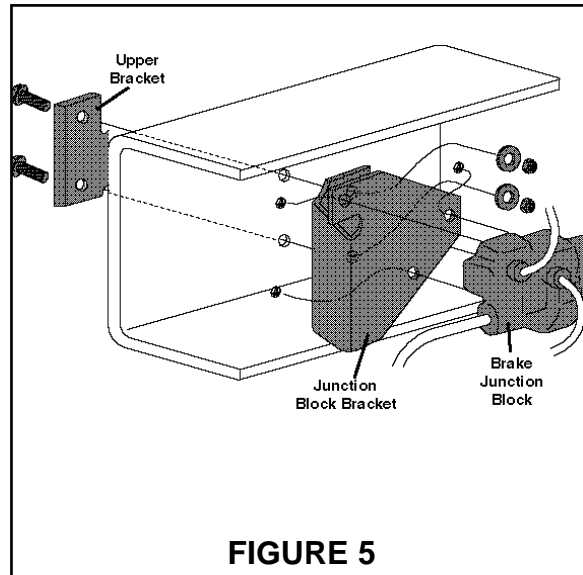

FIGURE 5

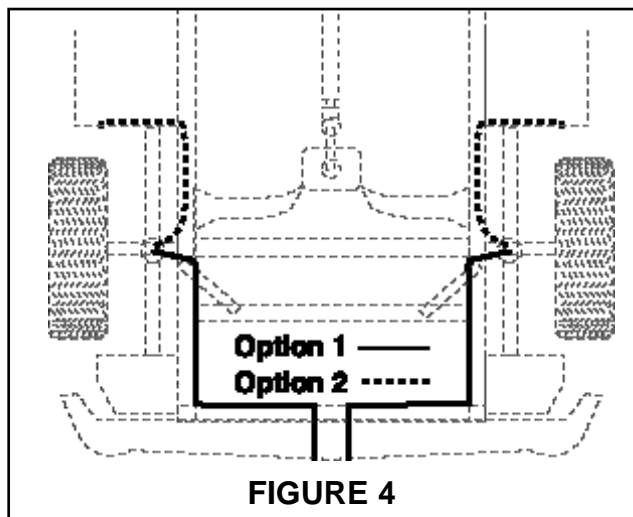

FIGURE 4

5. **NOTE:** If you had a brake injunction block use existing nuts, attach to bracket supplied. Then using upper bracket mounting hardware attach upper bracket and brake bracket as an assembly (SEE Figure 5). Install the upper bracket onto frame rail with the provided 3/8 bolts, washers, and locknuts and tighten 20 ft-lbs (Figure 1).
6. Line up sleeve perpendicular to upper and lower bracket and tighten upper nut to 15 ft-lbs. Install air fitting (this fitting is precoated with thread sealant) finger tight plus two turns. **Use a 7/16" open end wrench being careful to tighten on the metal hex nut only. DO NOT OVER TIGHTEN.** Orient the fitting so that it faces in the direction of your intended air line route.
7. Select a location for the inflation valves in the rear bumper area or rocker panel flange insuring that each valve will be protected and accessible with an air hose (Figure 6).
8. Use a standard tube cutter, a razor blade, or very sharp knife to cut the air line. A clean square cut will ensure against leaks. Cut the air line in two equal lengths, not more than 96" long. Drill 5/16" hole for inflation valve and mount as illustrated. Rubber washer on outside is for weather seal (Figure 6).
9. Route air line along frame to desired inflation valve location (Figure 6). Attach air line to chassis with the provided plastic straps.

TO PREVENT AIR LINE FROM MELTING, KEEP IT AT LEAST TWELVE INCHES FROM EXHAUST SYSTEM.

10. Cut off excess air line squarely. Install the air line into the fitting. This is a self locking fitting. Push and slightly turn the cut end of the air line into the fitting as far as it will go. You will hear/feel a definite "click" when the air line is seated. The air line is now installed. Air line should go in approximately 3/4 inch.
11. Repeat process for right side.
12. **VERY IMPORTANT** - With the bottom still loose, inflate the sleeve to approximately 10 p.s.i. By using the slotted adjustments, align the sleeve so that there is a symmetrical cushion of air around the lower base of the sleeve to prevent side load wear. Tighten the lower sleeve mounting bolt to 10 ft-lbs.
13. Inflate to 30 p.s.i. Check all fittings and valve core with a soapy water solution for leaks. Check once again to be sure you have proper clearance around the sleeve. When the sleeve is inflated there must be 1/2" of clearance all around the sleeve.
14. Recheck air pressure after 24 hours. A 2-4 p.s.i. loss after initial installation is normal. If pressure has dropped more than 5 lbs. re-test for leaks with soapy water solution. Please read and follow the Maintenance and Operating tips. (Check to see that the sleeve rolls back down over the bottom piston after the vehicle is lowered.)

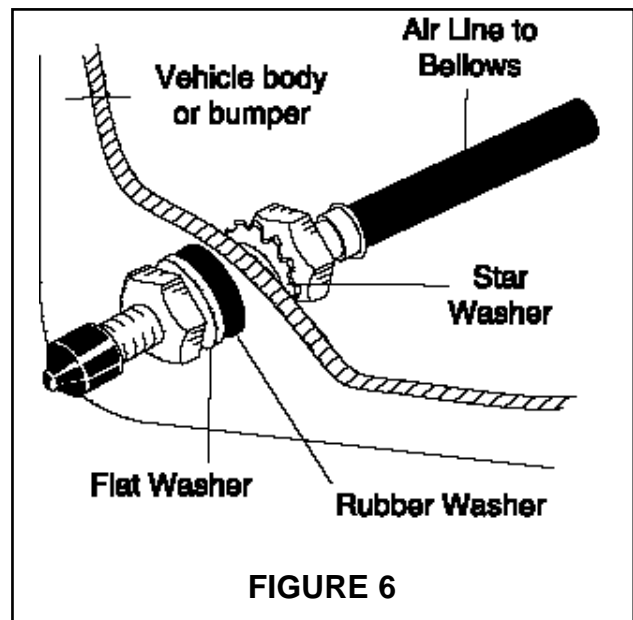
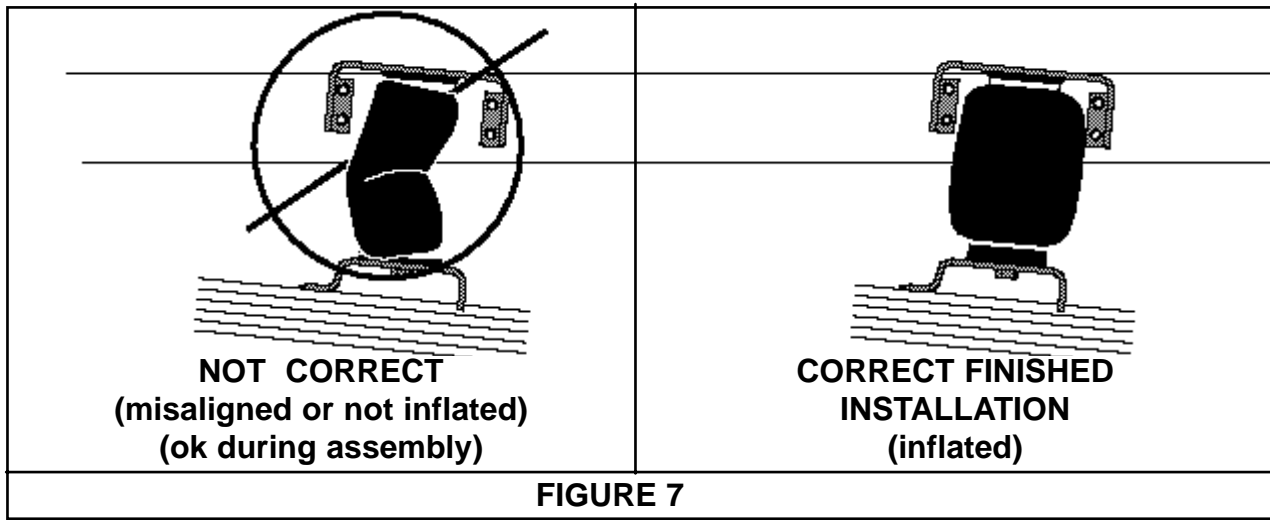

FIGURE 6



FAILURE TO MAINTAIN MINIMUM PRESSURE, BOTTOMING OUT, OR OVER EXTENSION WILL VOID THE WARRANTY

MAINTENANCE/OPERATION	
MINIMUM AIR PRESSURE 10 P.S.I.	MAXIMUM AIR PRESSURE 100 P.S.I.
MAINTENANCE	
<ol style="list-style-type: none"> 1. Check pressure weekly. 2. Always maintain at least 10 p.s.i. air pressure to prevent chafing. 3. If you develop an air leak in the system, use a soapy water solution to check all hose connections and the inflation valve core before removing sleeve. 	
OPERATING TIPS	
<ol style="list-style-type: none"> 1. Inflate your air springs to 60 p.s.i. before adding the payload. After vehicle is loaded, adjust your air pressure to level the vehicle and for ride comfort. 2. When you are carrying a payload it will be helpful to increase the tire inflation pressure in proportion to any overload condition. We recommend a 2 p.s.i. increase above normal (not to exceed tire manufacturer maximum) for each 100 lbs. total overload on the axle. 	
NOTE	
<ol style="list-style-type: none"> 1. IMPORTANT: For your safety and to prevent possible damage to your vehicle, do not exceed maximum load recommended by the vehicle manufacturer. Although your air springs are rated at maximum inflation pressure of 100 p.s.i., this pressure may represent too great of load on some vehicles. Check your vehicle owner's manual and do not exceed maximum loads listed for your vehicle. When inflating your Air Lift sleeves, add pressure in small quantities, checking pressure frequently during inflation. The sleeves require much less air volume than a tire and therefore inflate much quicker. 2. Should it become necessary to raise the vehicle by the frame, make sure the system is at minimum pressure (10psi) to reduce the tension on suspension/brake components. Check to see that the sleeve rolls back down over the bottom piston after the vehicle is lowered (Figure 7). If sleeve fails to roll back down over the piston, add air pressure until sleeve "pops" back over piston (do not exceed 100 p.s.i.). 	
	<p><i>Thank you for purchasing Air Lift Products</i></p> <p>AIR LIFT COMPANY P.O. BOX 80167 Lansing, MI 48908-0167</p>
FOR TECHNICAL ASSISTANCE CALL 1-800-248-0892	
Caution: DO NOT EXCEED THE VEHICLE MANUFACTURERS MAXIMUM GROSS VEHICLE WEIGHT RATING.	



Product Use Information

Frequently asked questions

Q. Will installing air springs increase the weight ratings of a vehicle?

No. Adding air springs will not change the weight ratings (GAWR, GCWR and/or GVWR) of a vehicle. Exceeding the GVWR is dangerous and voids the Air Lift warranty.

Q. Is it necessary to keep air in the air springs at all time and how much pressure will they need?

The minimum air pressure should be maintained at all times. The minimum air pressure keeps the air spring in shape, ensuring that it will move throughout its travel without rubbing or wearing on itself.

Q. Is it necessary to add a compressor system to the air springs?

No. Air pressure can be adjusted with any type of compressor as long as it can produce sufficient pressure to service the springs. Even a bicycle tire pump can be used, but it's a lot of work.

Q. How long should air springs last?

If the air springs are properly installed and maintained they can last indefinitely.

Q. Will raising the vehicle on a hoist for service work damage the air springs?

No. The vehicle can be lifted on a hoist for short-term service work such as tire rotation or an oil changes. However, if the vehicle will be on the hoist for a prolonged period of time, support the axle with jack stands in order to take the tension off of the air springs.

Tuning the air pressure

Pressure determination comes down to three things — level vehicle, ride comfort, and stability.

1. Level vehicle

If the vehicle's headlights are shining into the trees or the vehicle is leaning to one side, then it is not level (fig. 1). Raise the air pressure to correct either of these problems and level the vehicle.

2. Ride comfort

If the vehicle has a rough and harsh ride it may be due to either too much pressure or not enough. Try different pressures to determine the best ride comfort.

3. Stability

Stability translates into safety and should be the priority, meaning the driver may need to sacrifice a perfectly level and comfortable ride. Stability issues include roll control, bounce, dive during braking and sponginess (fig. 2). Tuning out these problems usually requires an increase in pressure.

fig. 1

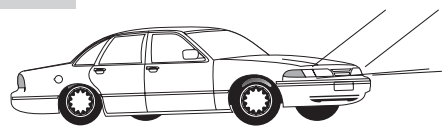

Bad headlight aim

fig. 2

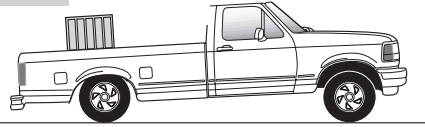

Unlevel, bottoming out

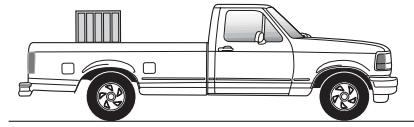

Level

Guidelines for adding air:

1. Start with the vehicle level or slightly above.
2. When in doubt, always add air.
3. For motorhomes, start with 50-100 p.s.i. in the rear because it can be safely assumed that it is heavily loaded.
4. If the front of the vehicle dives while braking, increase the pressure in the front air bags, if equipped.
5. If it is ever suspected that the air bags have bottomed out, increase the pressure (fig. 3).
6. Adjust the pressure up and down to find the best ride.
7. If the vehicle rocks and rolls, adjust the air pressure up and down to reduce the rocking and rolling.
8. It may be necessary to maintain different pressures on each side of the vehicle. Loads such as water, fuel, and appliances will cause the vehicle to be heavier on one side (fig. 4). As much as a 50 p.s.i. difference is not uncommon.

fig. 3

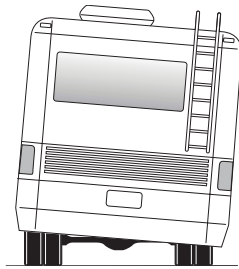

Poor stability

fig. 4

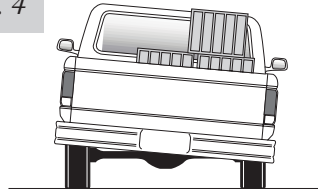

Unlevel

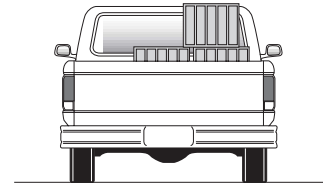

Level