

RIDE CONTROL

ADJUSTABLE AIR SPRING SUSPENSION

MN-251
(15906)
ECN2723

INSTALLATION INSTRUCTIONS P/N 59507

Figure 1 represents a TYPICAL installation. Your vehicle may look slightly different due to make, model or year.

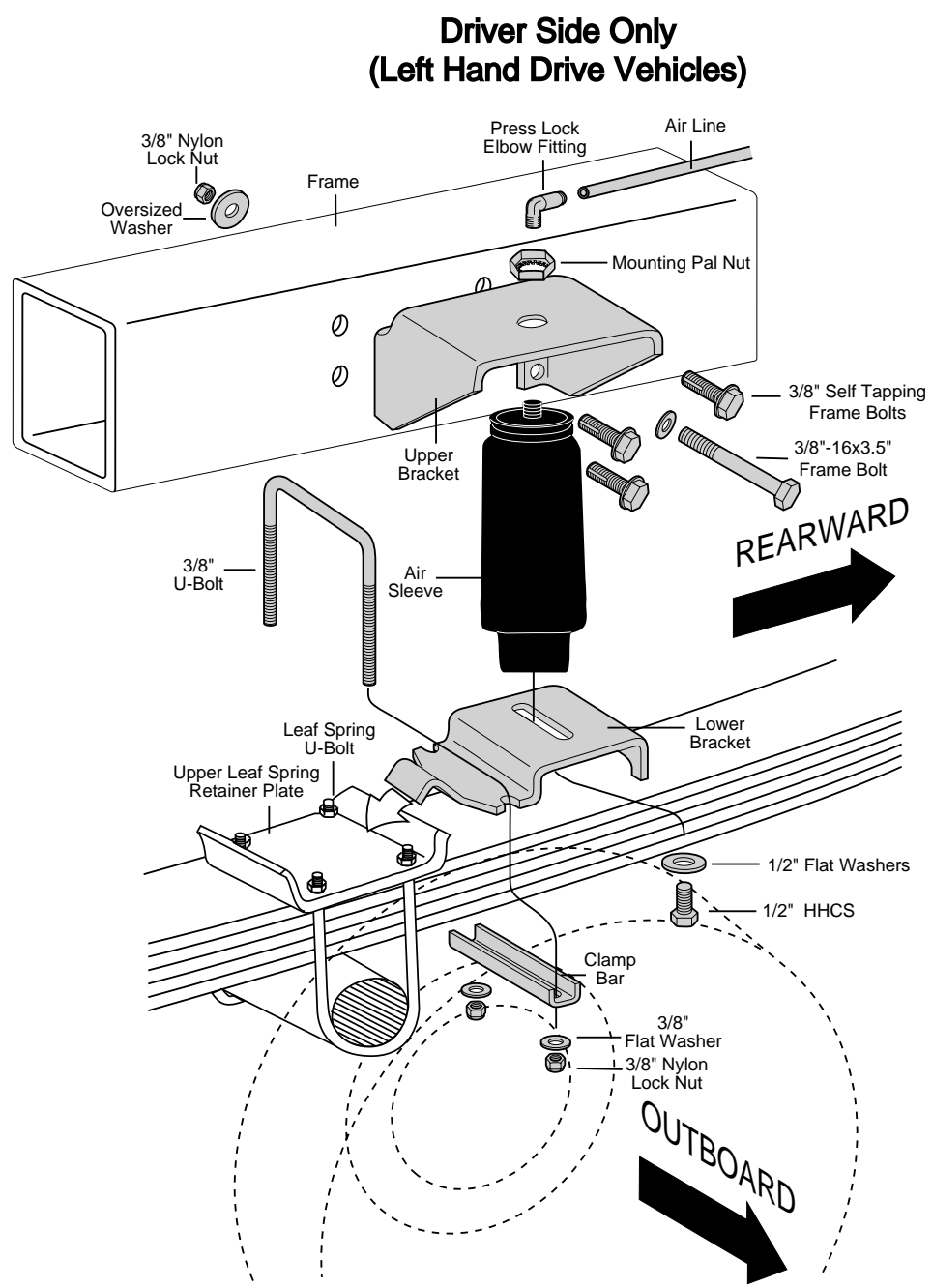

Figure 1

WARNING
DO NOT INFLATE ASSEMBLY WHEN IT IS UNRESTRICTED. ASSEMBLY MUST BE RESTRICTED BY SUSPENSION OR OTHER ADEQUATE STRUCTURE. DO NOT INFLATE BEYOND 100 P.S.I. IMPROPER USE OR OVER INFLATION MAY CAUSE ASSEMBLY TO BURST CAUSING PROPERTY DAMAGE OR SEVERE PERSONAL INJURY.

NORMAL RIDE HEIGHT: Normal ride height (no load)-This is defined as the distance between the bottom of the bumper and a flat road surface with the vehicle in "as delivered condition" (without a load, i.e. tool box, camper, etc.) measurements should be taken before beginning the installation. All of our kits are designed to be installed and operate at normal ride height.

IMPORTANT:

Your vehicle may be equipped with a rear brake proportioning valve. Any type of load assist suspension product could affect brake performance. We recommend that you check with your dealer before installing this type of product. If your vehicle does not have a proportioning valve or is equipped with an anti-lock brake system, no adjustment or modification is required.

REQUIRES MINIMUM CLEARANCE OF 5" BETWEEN TIRE AND FRAME (Figure 2).

1. Jack up rear of vehicle or raise on hoist and remove rear wheels. Raise axle or lower frame until the leaf spring is at normal ride height (no load).
2. LOOSELY attach the lower bracket to the bottom of the sleeve. Using the provided 1/2" flat washer and the 1/2" HHCS bolt as shown in Figure 1.
3. Now attach the lower bracket to the leaf spring as shown in Figure 1. The bracket will locate over the edge of the spring retainer plate (Figure 1). Tighten nuts to 20 ft-lbs on the 3/8 U-bolt.
4. Position the upper bracket so that the lower edge of the bracket legs are flush with the lower edge of the chassis rail (Figure 3). **If your vehicle is equipped with a fuel tank stone guard, the trailing edge of the upper bracket leg should rest on the flange of the fuel tank stone guard and overlap no more than 3/4" (Figure 3).** The normal mounted height of the sleeve should be between 5.5" and 7" tall. The kit must be mounted behind the axle. It may be necessary to trim the inner fender (plastic) to clear the air fitting.

IMPORTANT - In no case should the air sleeve be the suspension limiter in either extension or compression. Most vehicles will have a hard rubber compression stop on the rear suspension. The shock absorber is usually the limiter in full extension. The maximum extended length of the sleeve is 10.5" and the minimum compressed height is 2.2"

Sleeve diameter grows to 4.6" maximum at high pressure. Take this diameter into consideration when checking for possible interference in the mounting area. You must have sufficient clearance all around the sleeve at the maximum diameter.

Failure to maintain minimum air pressure of 10 p.s.i. in the air sleeve, bottoming out, or over extension will void the warranty.

5. **The driver side (US) will require the use of three 3/8 self tapping frame bolts (Figure 1).** Drill 5/16" holes to install these bolts. The fourth bolt (Lower, rear hole) is a 3/8-16x3.5" frame bolt that will go all the way through the frame attached by a washer and locknut on the other side and tightened to 20 ft-lbs. Drill a 3/8" hole for this bolt (Figure 1).
6. **The passenger side (US) uses four 3/8-16x3.5" frame bolts mounted through the frame rail as shown in Figure 4.**

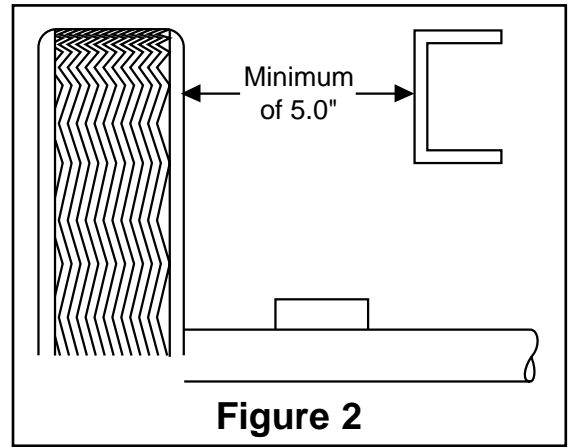

Before starting this installation, carefully measure the distance between the frame and inner part of the tire when vehicle is at normal height.

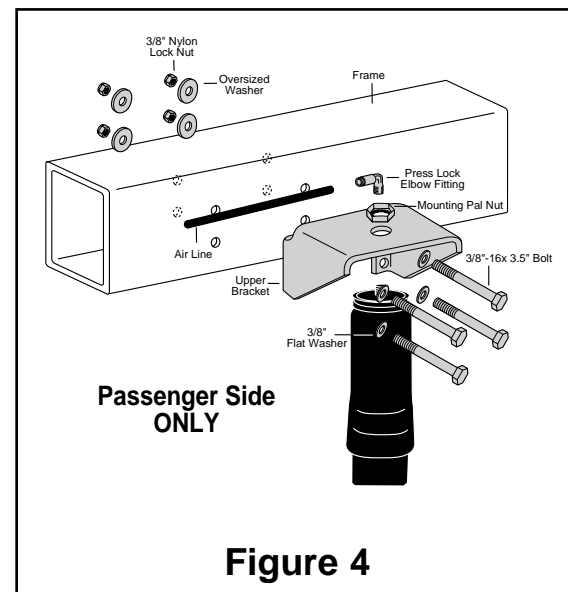
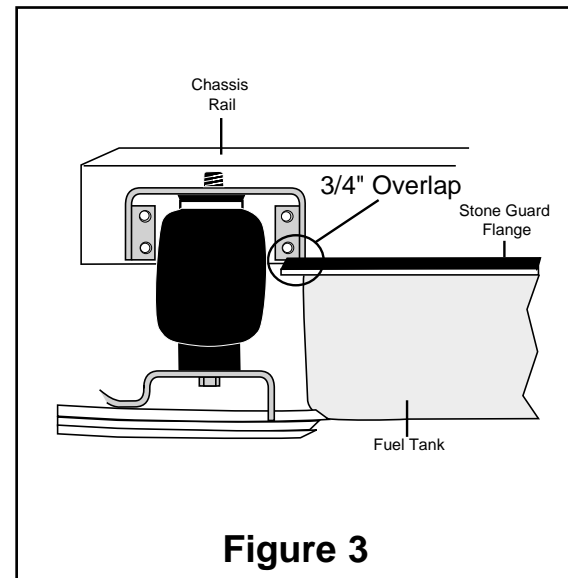

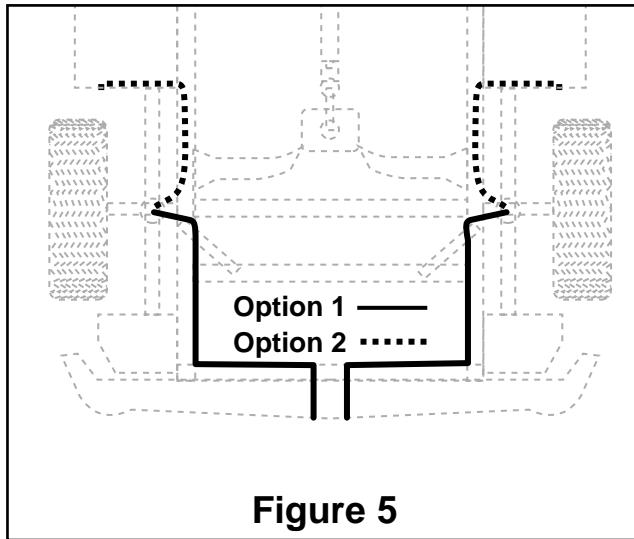

CAUTION: DO NOT DRILL HOLES INTO THE FRAME UNTIL ANY HYDRAULIC LINES, GAS LINE AND ELECTRICAL WIRES HAVE BEEN MOVED ASIDE ON BOTH SIDES OF FRAME RAIL.

7. Tighten the sleeve upper mounting pal nut (flange up) to 15 ft-lbs. Install the air fitting (this fitting is precoated with thread sealant) finger tight plus two turns. **Use a 7/16" open end wrench being careful to tighten on the metal hex nut only. DO NOT OVER TIGHTEN.** Orient the fitting so that it faces in the direction of your intended air line route.
8. Select a location for the inflation valves in the rear bumper area or rocker panel flange insuring that each valve will be protected and accessible with an air hose (Figure 5).
9. Cut the air line in two equal lengths. Use a standard tube cutter, a razor blade, or very sharp knife to cut the air line. A clean square cut will ensure against leaks. Drill 5/16" hole for inflation valve and mount as illustrated. Rubber washer on outside is for weather seal (Figure 6).
10. Route air line along frame to desired inflation valve location (Figure 5). Attach air line to chassis with the provided plastic straps.

TO PREVENT AIR LINE FROM MELTING, KEEP IT AT LEAST TWELVE INCHES FROM EXHAUST SYSTEM.

11. Cut off excess air line squarely and install the air line into the fitting. This is a self locking fitting. Push and slightly turn the cut end of the air line into the fitting as far as it will go, approximately 3/4". You will hear/feel a definite "click" when the air line is seated. The air line is now installed.
12. Repeat process for right side and return to step 12.

13. **VERY IMPORTANT** - With the bottom still loose, inflate the sleeve to approximately 10 p.s.i. By using the slotted adjustment, center the sleeve so that it is in line with the upper and lower bracket and that there is a symmetrical cushion of air around the lower base of the sleeve to prevent side load wear. Sleeve diameter grows to 4.6" at maximum inflation, check to be sure there is sufficient clearance around the sleeve when it is inflated. **Tighten the lower sleeve mounting bolt to 10 ft-lbs. Do not over tighten.**

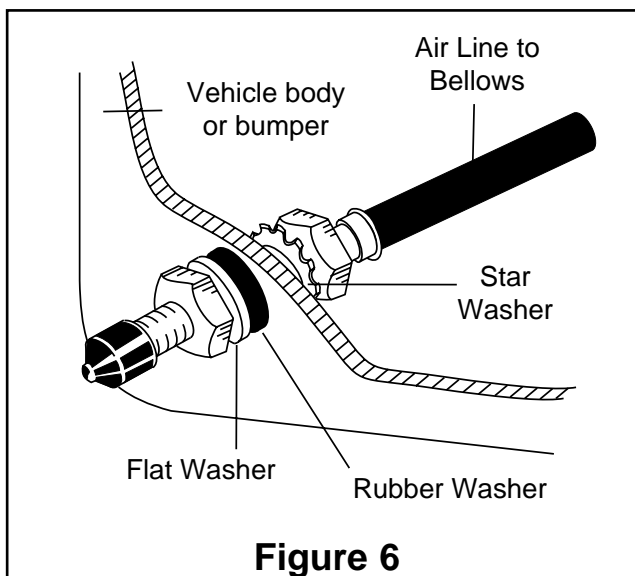

14. Inflate to 30 p.s.i. Check all fittings and valve core with a soapy water solution for leaks. Check once again to be sure you have proper clearance around the sleeve. When the sleeve is inflated there must be sufficient clearance all around the sleeve.
15. Recheck air pressure after 24 hours. A 2-4 p.s.i. loss after initial installation is normal. If pressure has dropped more than 5 lbs. re-test for leaks with soapy water solution. Please read and follow the Maintenance and Operating Tips. **(Make sure that the sleeve rolls back down over the bottom piston after the vehicle is lowered.)**

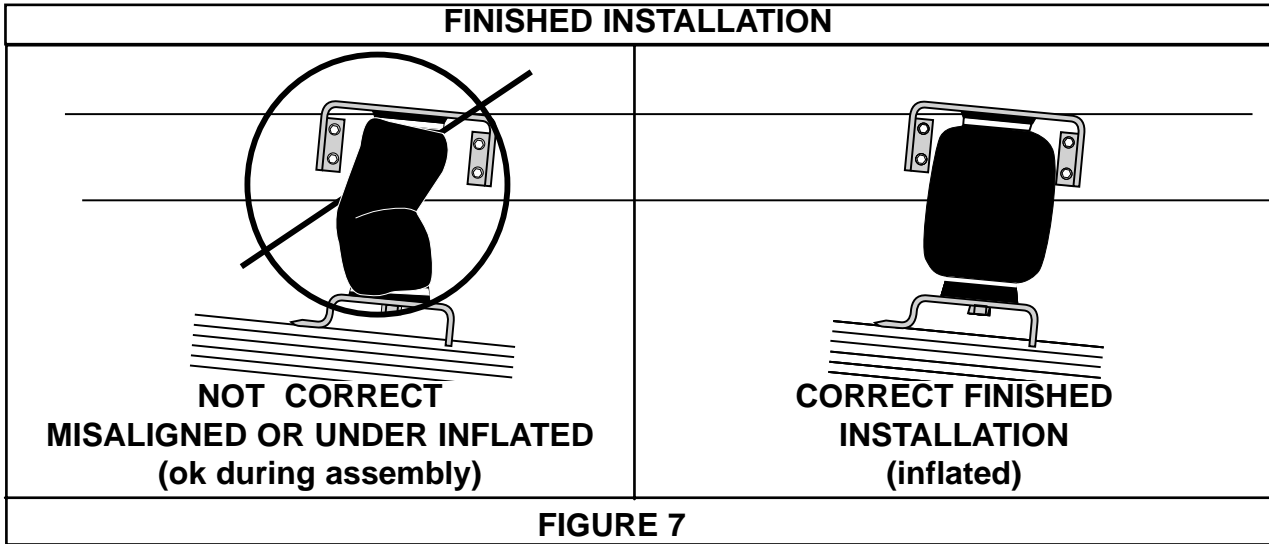

**FAILURE TO MAINTAIN MINIMUM PRESSURE, BOTTOMING OUT, OR OVER
EXTENSION WILL VOID THE WARRANTY**

MAINTENANCE/OPERATION	
MINIMUM AIR PRESSURE 10 P.S.I.	MAXIMUM AIR PRESSURE 100 P.S.I.
MAINTENANCE	
<ol style="list-style-type: none"> 1. Check pressure weekly. 2. Always maintain at least 10 p.s.i. air pressure to prevent chafing. 3. If you develop an air leak in the system, use a soapy water solution to check all air line connections and the inflation valve core before removing sleeve. 	
OPERATING TIPS	
<ol style="list-style-type: none"> 1. Inflate your air springs to 60 p.s.i. before adding the payload. After vehicle is loaded, adjust your air pressure to level the vehicle and for ride comfort. 2. When you are carrying a payload it will be helpful to increase the tire inflation pressure in proportion to any overload condition. We recommend a 2 p.s.i. increase above normal (not to exceed tire manufacturer maximum) for each 100 lbs. total overload on the axle. 	
NOTE	
<ol style="list-style-type: none"> 1. IMPORTANT: For your safety and to prevent possible damage to your vehicle, do not exceed maximum load recommended by the vehicle manufacturer. Although your air springs are rated at maximum inflation pressure of 100 p.s.i., this pressure may represent too great of load on some vehicles. Check your vehicle owner's manual and do not exceed maximum loads listed for your vehicle. When inflating your Air Lift sleeves, add pressure in small quantities, checking pressure during inflation. The sleeves require much less air volume than a tire and therefore inflate much faster. 2. Should it become necessary to raise the vehicle by the frame, make sure the system is at minimum pressure (10psi) to reduce the tension on suspension/brake components. Check to see that the sleeve rolls back down over the bottom piston after the vehicle is lowered (Figure 7). If sleeve fails to roll back down over the piston, add air pressure until sleeve "pops" back over piston (do not exceed 100 p.s.i.). 	
	<p><i>Thank you for purchasing Air Lift Products</i></p> <p>AIR LIFT COMPANY P.O. BOX 80167 Lansing, MI 48908-0167</p>
FOR TECHNICAL ASSISTANCE CALL 1-800-248-0892	
Caution: DO NOT EXCEED THE VEHICLE MANUFACTURERS MAXIMUM GROSS VEHICLE WEIGHT RATING.	



Product Use Information

Frequently asked questions

Q. Will installing air springs increase the weight ratings of a vehicle?

No. Adding air springs will not change the weight ratings (GAWR, GCWR and/or GVWR) of a vehicle. Exceeding the GVWR is dangerous and voids the Air Lift warranty.

Q. Is it necessary to keep air in the air springs at all time and how much pressure will they need?

The minimum air pressure should be maintained at all times. The minimum air pressure keeps the air spring in shape, ensuring that it will move throughout its travel without rubbing or wearing on itself.

Q. Is it necessary to add a compressor system to the air springs?

No. Air pressure can be adjusted with any type of compressor as long as it can produce sufficient pressure to service the springs. Even a bicycle tire pump can be used, but it's a lot of work.

Q. How long should air springs last?

If the air springs are properly installed and maintained they can last indefinitely.

Q. Will raising the vehicle on a hoist for service work damage the air springs?

No. The vehicle can be lifted on a hoist for short-term service work such as tire rotation or oil changes. However, if the vehicle will be on the hoist for a prolonged period of time, support the axle with jack stands in order to take the tension off of the air springs.

Tuning the air pressure

Pressure determination comes down to three things — level vehicle, ride comfort, and stability.

1. Level vehicle

If the vehicle's headlights are shining into the trees or the vehicle is leaning to one side, then it is not level (fig. 1). Raise the air pressure to correct either of these problems and level the vehicle.

2. Ride comfort

If the vehicle has a rough and harsh ride it may be due to either too much pressure or not enough (fig. 2). Try different pressures to determine the best ride comfort.

3. Stability

Stability translates into safety and should be the priority, meaning the driver may need to sacrifice a perfectly level and comfortable ride. Stability issues include roll control, bounce, dive during braking and sponginess (fig. 3). Tuning out these problems usually requires an increase in pressure.

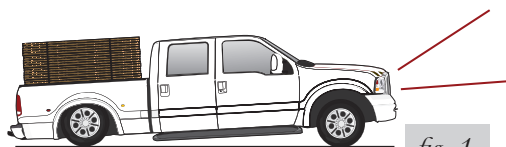

Bad headlight aim



Sway and body roll



Rough ride

Guidelines for adding air:

1. Start with the vehicle level or slightly above.
2. When in doubt, always add air.
3. For motorhomes, start with 50-100 PSI in the rear because it can be safely assumed that it is heavily loaded.
4. If the front of the vehicle dives while braking, increase the pressure in the front air bags, if equipped.
5. If it is ever suspected that the air bags have bottomed out, increase the pressure (fig. 4).
6. Adjust the pressure up and down to find the best ride.
7. If the vehicle rocks and rolls, adjust the air pressure to reduce movement.
8. It may be necessary to maintain different pressures on each side of the vehicle. Loads such as water, fuel, and appliances will cause the vehicle to be heavier on one side (fig. 5). As much as a 50 PSI difference is not uncommon.

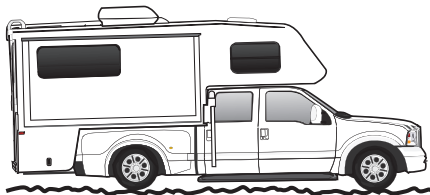

Bottoming out

fig. 4

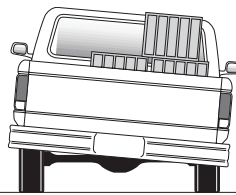

Unlevel

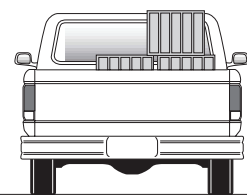

Level

fig. 5

Warranty and Returns Policy

Air Lift Company warrants its products, for the time periods listed below, to the original retail purchaser against manufacturing defects when used on catalog-listed applications on cars, vans, light trucks and motorhomes under normal operating conditions for as long as Air Lift manufactures the product. The warranty does not apply to products that have been improperly applied, improperly installed, used in racing or off-road applications, used for commercial purposes, or which have not been maintained in accordance with installation instructions furnished with all products. The consumer will be responsible for removing (labor charges) the defective product from the vehicle and returning it, transportation costs prepaid, to the dealer from which it was purchased or to Air Lift Company for verification.

Air Lift will repair or replace, at its option, defective products or components. A minimum \$10.00 shipping and handling charge will apply to all warranty claims. Before returning any defective product, you must call Air Lift at (800) 248-0892 in the U.S. and Canada (elsewhere, (517) 322-2144) for a Returned Materials Authorization (RMA) number. Returns to Air Lift can be sent to: Air Lift Company • 2727 Snow Road • Lansing, MI • 48917.

Product failures resulting from abnormal use or misuse are excluded from this warranty. The loss of use of the product, loss of time, inconvenience, commercial loss or consequential damages is not covered. The consumer is responsible for installation/reinstallation (labor charges) of the product. Air Lift Company reserves the right to change the design of any product without assuming any obligation to modify any product previously manufactured.

This warranty gives you specific legal rights and you may also have other rights that vary from state-to-state. Some states do not allow limitations on how long an implied warranty lasts or allow the exclusion or limitation of incidental or consequential damages. The above limitation or exclusion may not apply to you. There are no warranties, expressed or implied including any implied warranties of merchantability and fitness, which extend beyond this warranty period. There are no warranties that extend beyond the description on the face hereof. Seller disclaims the implied warranty of merchantability. (Dated proof of purchase required.)

Air Lift 1000	Lifetime Limited
RideControl	Lifetime Limited
SlamAir	Lifetime Limited
LoadLifter 5000*	Lifetime Limited
EasyStreet Systems	1 Year Limited

Load Controller (I)	2 Year Limited
Load Controller (II)	2 Year Limited
SmartAir	2 Year Limited
Wireless AIR	2 Year Limited
Other Accessories	2 Year Limited

**formerly SuperDuty*