

Please read these instructions completely before proceeding with the installation.

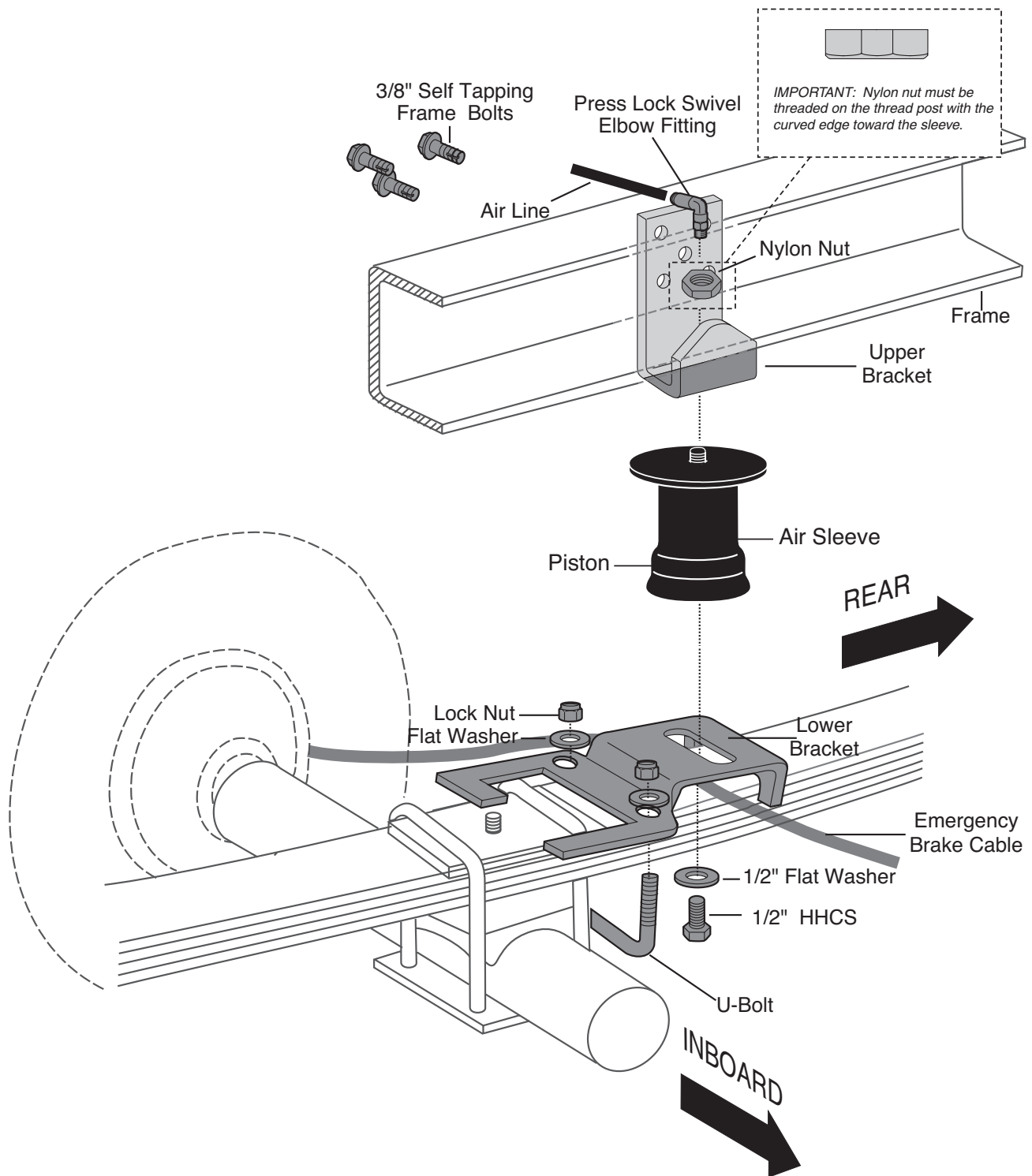

Figure 1

CAUTION: Do not inflate the assembly when it is unrestricted. Assembly must be restricted by suspension or other adequate structure. Do not inflate beyond 100 P.S.I. Improper use or overinflation may cause assembly to burst, causing property damage or severe personal injury.

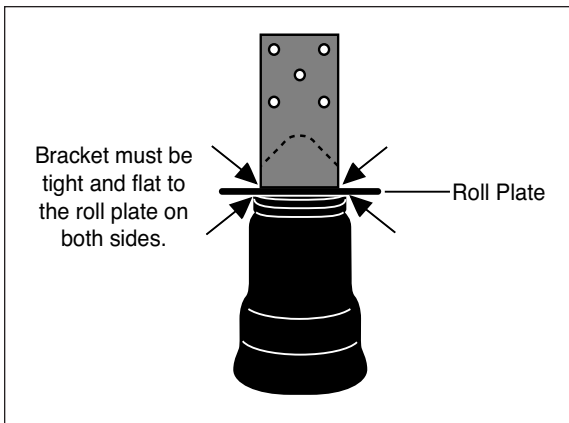

Figure 2

CAUTION: Failure to maintain correct minimum pressure (or pressure proportional to the load), bottoming out, over-extension, or rubbing against another component will void the warranty. Normal ride height, regardless of load, must always be maintained.

IMPORTANT: Your vehicle may be equipped with a rear brake proportioning valve. Any type of load assist product could affect brake performance. If equipped with a brake proportioning valve, we recommend that you check with your dealer before installing this type of product. If your vehicle does not have a rear brake proportioning valve or is equipped with an anti-lock type brake system, installation of a load assist product will have no effect on brake system performance.

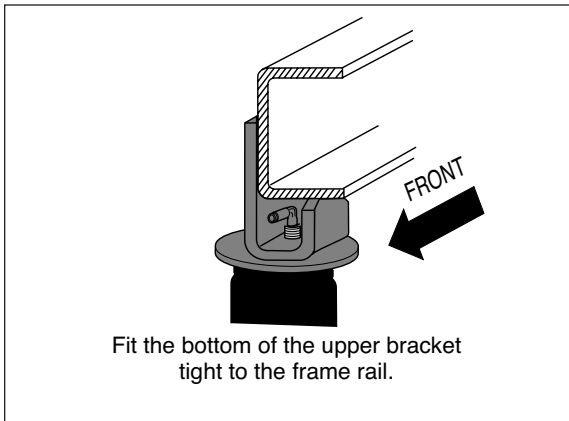

Figure 3

I. Getting Started

1. Determine the Ride Height. This is defined as the distance between the bottom edge of the fenderwell to the center point of the wheel with the vehicle at the desired height (without a load). Measurements should be taken before beginning the installation. The distance from the bottom edge of the fenderwell to the center point of the wheel should be recorded. All of our kits are designed to be installed and operate at normal ride height.

2. Measure the ride height distance. Enter the measurement below:

Ride Height: _____ inches

3. After measuring and recording the ride height, jack up rear of vehicle or raise on hoist. Raise axle or lower frame until the leaf spring is at ride height (unloaded condition).

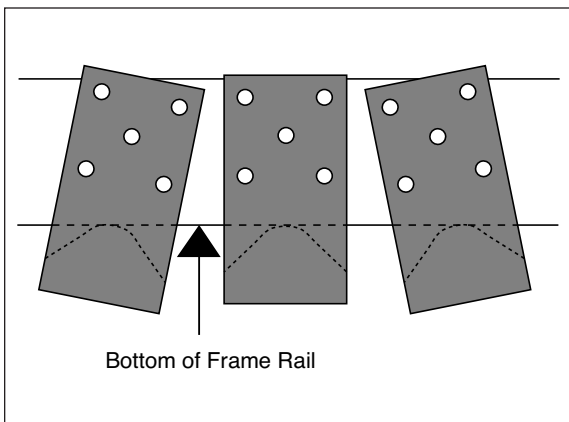

Figure 4

II. Installing the Lower Bracket

Tacoma 4WD: Air springs will mount forward of the axle.

4WD Extended Cab Mini Truck & 4-Runner: Air springs will mount behind the axle.

1. Assemble the kit. Install the air fitting finger tight plus two turns. This fitting is precoated with thread sealant. Use an open end wrench being careful to tighten on the metal hex nut only. **DO NOT OVERTIGHTEN.**

2. Thread the attached air fitting through the bottom of the J-bracket. Position the elbow towards the front of the vehicle for proper air line routing (Figure 1). Slide the provided nylon nut over the air fitting and onto the threaded post. Tighten the nylon nut hand tight to secure the bracket (Figure 4).

NOTE: The nylon nut must be threaded on the thread post with the curved edge facing toward the sleeve (Figure 1).

3. **LOOSELY** attach the lower bracket to the bottom of the sleeve using a 1/2" bolt and 1/2" flat washer (Figure 1). Set the assembly on the leaf spring.

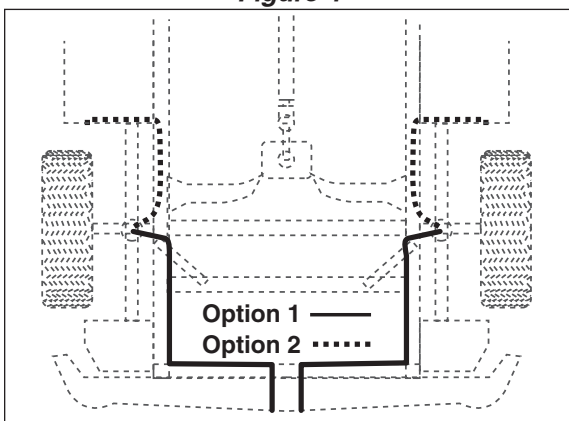

Figure 5

NOTE: The lower bracket will go OVER the U-bolts. Secure to the leaf springs using the provided U-bolts, flat washers and nylon lock nuts (Figure 1). Tighten to 20 ft.lbs.

- To install the upper bracket, lower the axle or raise the frame until the upper bracket is in line with the lower and on the same angle as the leaf spring. The bottom of the upper bracket must fit tight to the bottom of the frame rail (Figure 3). The upper bracket must be parallel and perpendicular to the lower bracket. The upper bracket is designed so that it can be tilted for the proper angle.
- It is necessary to use at least three of the five pre-drilled mounting holes on the upper bracket. Any combination of three is permissible.

NOTE: There is a shock bracket on the inside frame rail, passenger side of the Tacoma. Take this into consideration when choosing mounting holes for the upper bracket.

- Using the bracket as a template, center punch and drill three 5/16" holes. **The holes must be no larger than 5/16".** Attach the upper bracket using the Self-Tapping Frame Bolts and tighten to 15 ft.lbs. (Figure 1). **DO NOT OVERTIGHTEN.**

CAUTION: Do not drill holes into the frame until any and all hydraulic, fuel, or electrical lines have been moved or shielded.

IMPORTANT: Your air springs will live much longer if they are not the suspension limiter in either compression or extension. The air spring compresses to 2.2" and extends to 7.1". Keeping the minimum required pressure or a pressure proportional to the load will prevent bottoming out. The shock absorber is usually the limiter on extension. If this is not the case, you should consider the use of limiting straps, especially if the vehicle is used off-road. The maximum inflated diameter of your air-spring is 4.6". You must check to see that nothing is rubbing against the air spring within this diameter.

- Select a location for the inflation valves in the rear bumper area or rocker panel flange ensuring that each valve will be protected and accessible with an air hose (Figure 5). Drill a 5/16" hole for the inflation valve and mount as illustrated. The outer rubber washer is used as a weather seal (Figure 6).

CAUTION: To prevent the air line from melting, keep it at least 12 inches from the exhaust system.

- Use a standard tube cutter or razor blade to cut the air line into two equal lengths. A clean square cut will ensure against leaks. Install the air line into the fitting. Push and slightly turn the cut end of the air line into the fitting as far as it will go (approximately 9/16"). A definite "click" can be heard and/or felt when the air line is seated. The air line is now installed.
- Repeat steps 1-8 for the other side of the vehicle.
- VERY IMPORTANT: With the bottom still loose, inflate the sleeve to approximately 10 p.s.i. By using the slotted adjustment, center the sleeve so that it is in line with the upper and lower brackets and that there is a symmetrical cushion of air around the lower piston of the sleeve to prevent side load wear. Sleeve diameter grows to 4.6" at maximum inflation. Check to be sure there is sufficient clearance around the sleeve when it is inflated. Tighten the lower sleeve mounting bolt to 10 ft.lbs. DO NOT OVERTIGHTEN.**
- Inflate to 30 p.s.i. Check all fittings and valve core for leaks with a soapy water solution. Recheck air pressure after 24 hours. A 2-4 p.s.i. loss after initial installation is normal. If pressure has dropped more than 5 lbs retest for leaks with soapy water solution. Please read and follow the Maintenance and Operations sections.

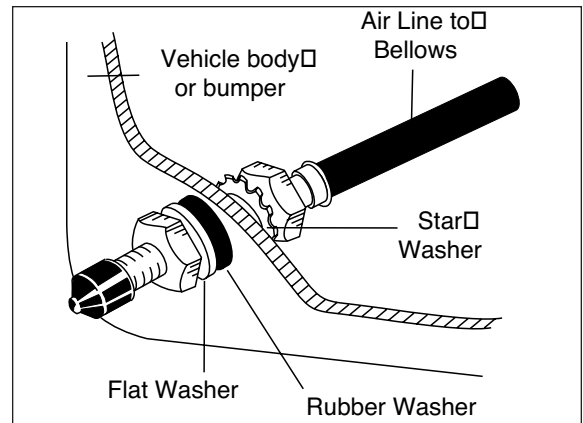

Figure 6

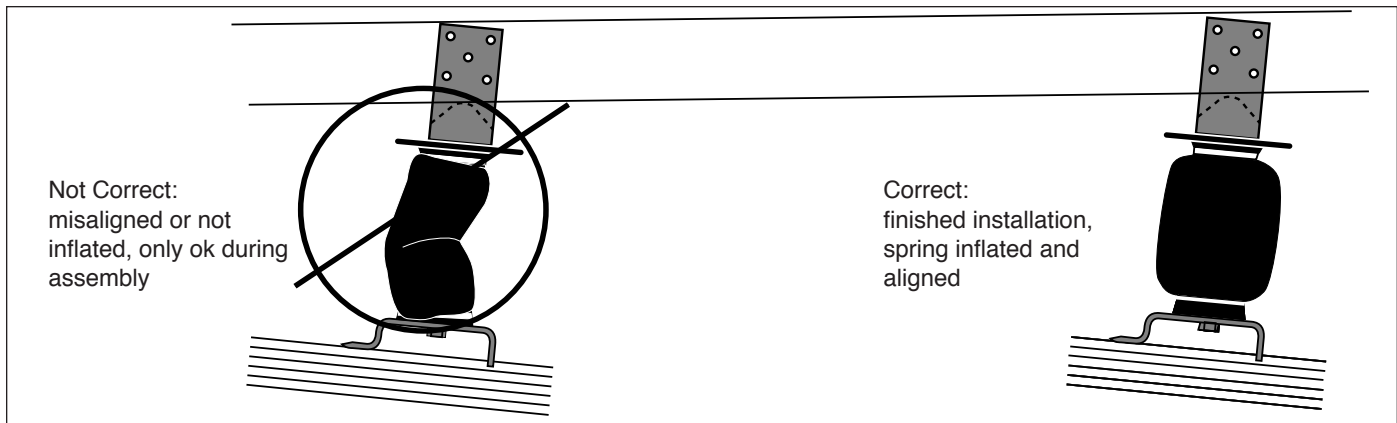

Figure 9

MINIMUM AIR PRESSURE	MAXIMUM AIR PRESSURE
5 p.s.i.	100 p.s.i.
<p><i>Failure to maintain correct minimum pressure (or pressure proportional to load), bottoming out, over-extension, or rubbing against another component will void the warranty.</i></p> <p><i>Regardless of load, the air pressure must always be adjusted so that the normal ride height is maintained at all times.</i></p>	

Maintenace of the System

1. Check pressure weekly.
2. Always maintain at least 5 p.s.i. air pressure.
3. If you develop an air leak in the system, use a soapy water solution to check all air line connections and the inflation valve core before removing sleeve.

Operation of the System

1. Inflate your air springs to 60 p.s.i. before adding the payload. After vehicle is loaded, adjust your air pressure to level the vehicle.
2. **IMPORTANT:** For your safety and to prevent possible damage to your vehicle, do not exceed maximum load recommended by the vehicle manufacturer. Although your air springs are rated at maximum inflation pressure of 100 p.s.i., the air pressure actually needed is dependant on the load and Gross Vehicle Weight Rating (GVWR), which may be less than 100 p.s.i. Check your vehicle ownerís manual and do not exceed maximum loads listed for your vehicle.
3. When inflating your Air Lift sleeves, add pressure in small quantities, check the pressure frequently during inflation. The sleeves require much less air volume than a tire and therefore inflate much faster.
4. Should it become necessary to raise the vehicle by the frame, make sure the system is at minimum pressure (5 p.s.i.) to reduce the tension on suspension/brake components. Check to see that the air spring rolls back down over the bottom piston after the vehicle is lowered (Figure 9). If sleeve fails to roll back down over the piston, add air pressure until sleeve “pops” back over piston (do not exceed 100 p.s.i.).



Thank you for purchasing Air Lift Products

Mailing Address:
AIR LIFT COMPANY
P.O. Box 80167
Lansing, MI 48908-0167

Street Address:
AIR LIFT COMPANY
2727 Snow Rd.
Lansing, MI 48917

Local Phone: (517) 322-2144
Fax: (517) 322-0240

For Technical Assistance call 1-800-248-0892

“The Choice of the Professional Installer”

Printed in the USA