

P/N 59510

Please read these instructions completely before proceeding with the installation.

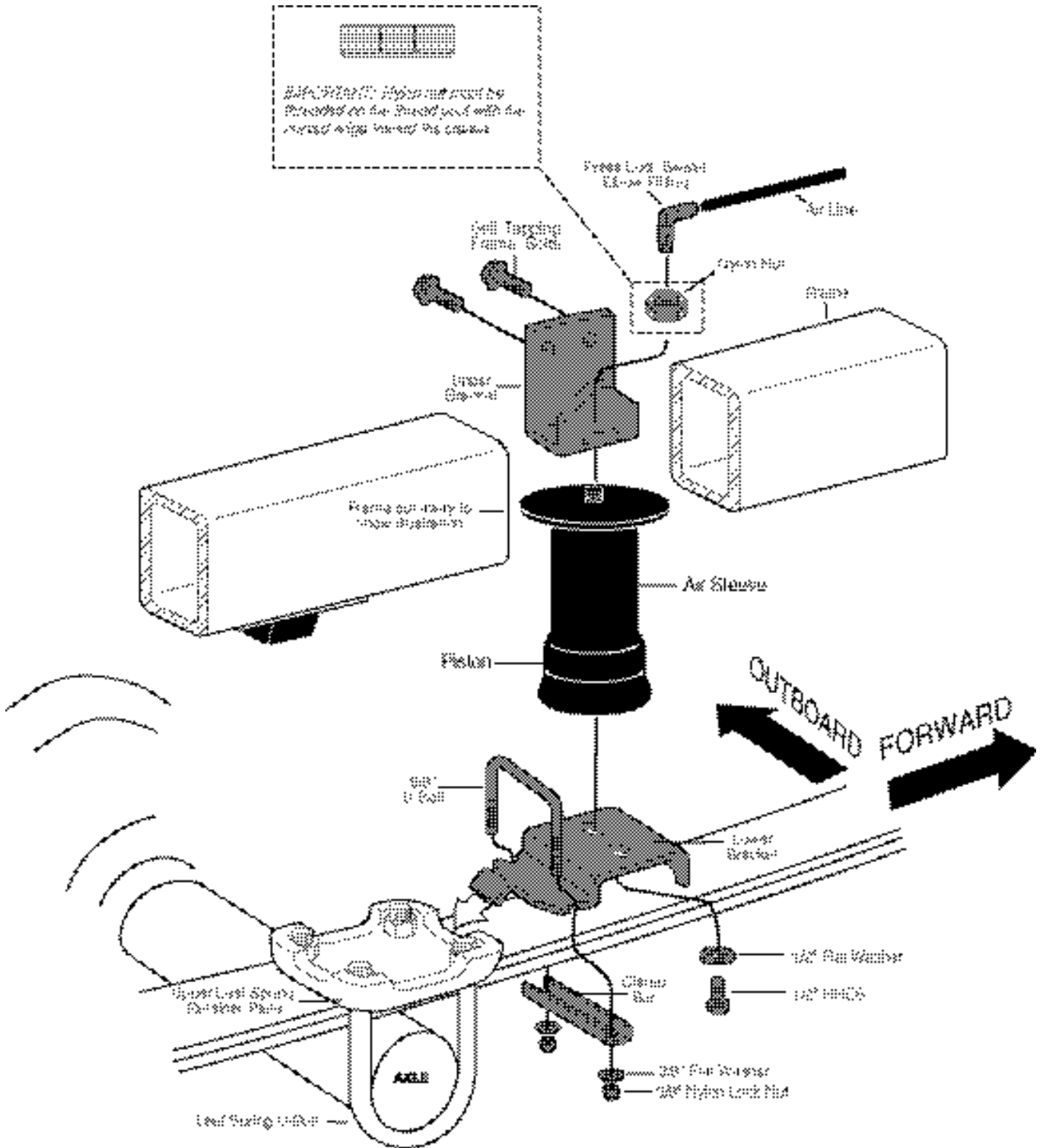
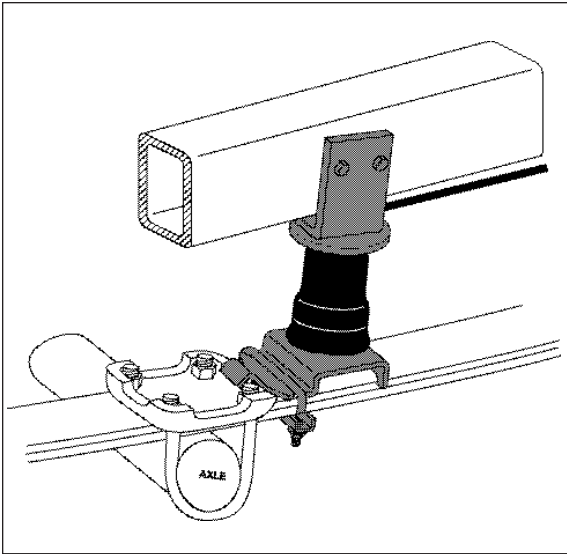

Figure 1



Inset A

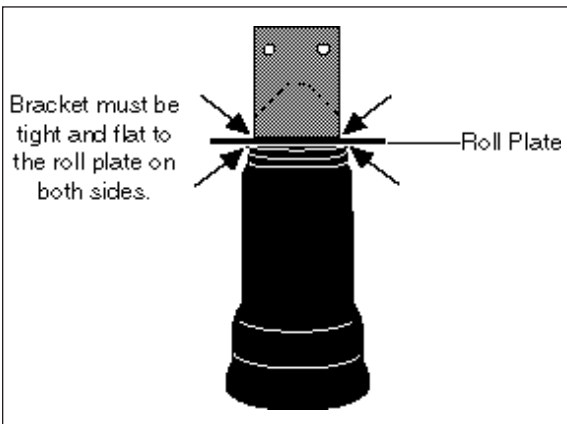

Figure 2

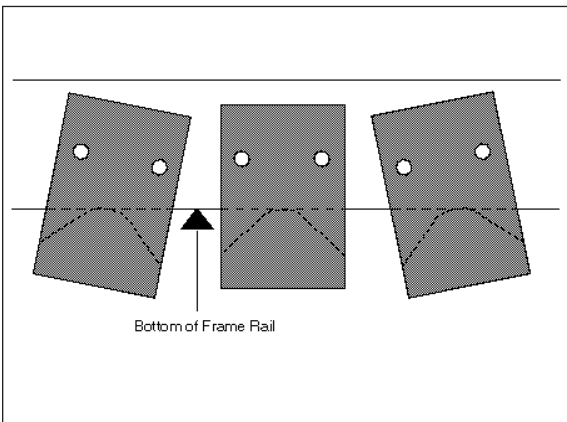

Figure 3

CAUTION: Failure to maintain correct minimum pressure (or pressure proportional to the load), bottoming out, over-extension, or rubbing against another component will void the warranty. Normal ride height, regardless of load, must always be maintained.

IMPORTANT: Your vehicle may be equipped with a rear brake proportioning valve. Any type of load assist product could affect brake performance. If equipped with a brake proportioning valve, we recommend that you check with your dealer before installing this type of product. If your vehicle does not have a rear brake proportioning valve or is equipped with an anti-lock type brake system, installation of a load assist product will have no effect on brake system performance.

I. Getting Started

1. Determine the Ride Height. This is defined as the distance between the bottom edge of the fenderwell to the center point of the wheel with the vehicle at the desired height (without a load). Measurements should be taken before beginning the installation. The distance from the bottom edge of the fenderwell to the center point of the wheel should be recorded. All of our kits are designed to be installed and operate at normal ride height.
2. Measure the ride height distance. Enter the measurement below:

Ride Height: _____ inches
3. After measuring and recording the ride height, jack up rear of vehicle or raise on hoist. Raise axle or lower frame until the leaf spring is at ride height (unloaded condition).

II. Installing the Lower Bracket

1. Assemble the kit. Install the air fitting finger tight plus two turns. This fitting is precoated with thread sealant. Use an open end wrench being careful to tighten on the metal hex nut only. **DO NOT OVERTIGHTEN.**
2. Thread the attached air fitting through the bottom of the J-bracket. Position the elbow towards the front or rear of vehicle depending on which direction will allow easier access for the air line (Figures 1 and 2). Slide the provided nylon nut over the air fitting and onto the threaded post. Tighten the nylon nut hand tight to secure the bracket (Figure 4).

NOTE: The nylon nut must be threaded on the thread post with the curved edge facing toward the sleeve (Figure 1).

3. Note that the lower bracket has two mounting holes. Using the outboard hole on each side, **LOOSELY** attach the lower brackets to the bottom of the sleeve with the provided 1/2" flat washer and 1/2" bolt as shown in Figure 1.
4. Now install the lower bracket as shown in Figure 1. The bracket locates over the edge of the upper spring retainer (INSET A).

Tighten nuts to 20 ft.lbs. **DO NOT OVERTIGHTEN.**

CAUTION: Do not drill holes into the frame until any hydraulic lines, gas lines and electrical wires have been moved aside on both sides of the frame rail.

5. To install the upper bracket, lower the axle or raise the frame until the upper bracket is in line with the lower and on the same angle as the leaf spring. The lower mounting surface of the upper bracket must be parallel to the mounting surface of the lower bracket and the sleeve should be straight when installed between the brackets. The upper bracket is designed so that it can be tilted for the proper angle (Figure 3). The bottom of the upper bracket must fit tight to the bottom of the frame rail (Figure 4). Using the bracket as a template, center punch and drill three 5/16" holes. The holes must be no larger than 5/16". Attach the upper bracket using the Self-Tapping Frame Bolts and tighten securely (Figure 1). **DO NOT OVERTIGHTEN.**
6. Select a location for the inflation valves in the rear bumper area or rocker panel flange ensuring that each valve will be protected and accessible with an air hose (Figure 5).
7. Use a standard tube cutter or razor blade to cut the air line into two equal lengths. A clean square cut will ensure against leaks. Drill a 5/16" hole for the inflation valve and mount as illustrated. The outer rubber washer is used as a weather seal (Figure 6).
8. Route air line along frame from inflation valve location to the air fitting (Figures 1 and 5). Attach air line to chassis with the provided plastic straps.

CAUTION: To prevent the air line from melting, keep it at least 12 inches from the exhaust system.

9. Install the air line into the fitting. Push and slightly turn the cut end of the air line into the fitting as far as it will go (approximately 9/16"). A definite "click" can be heard and/or felt when the air line is seated. The air line is now installed.
10. Repeat steps 1-9 for the other side of the vehicle.
11. **VERY IMPORTANT: With the bottom still loose, inflate the sleeve to approximately 10 p.s.i. By using the slotted adjustment, center the sleeve so that it is in line with the upper and lower brackets and that there is a symmetrical cushion of air around the lower piston of the sleeve to prevent side load wear. Sleeve diameter grows to 5.1" at maximum inflation. Check to be sure there is sufficient clearance around the sleeve when it is inflated. Tighten the lower sleeve mounting bolt to 10 ft.lbs. DO NOT OVERTIGHTEN.**
12. Inflate to 30 p.s.i. Check all fittings and valve core for leaks with a soapy water solution. Recheck air pressure after 24

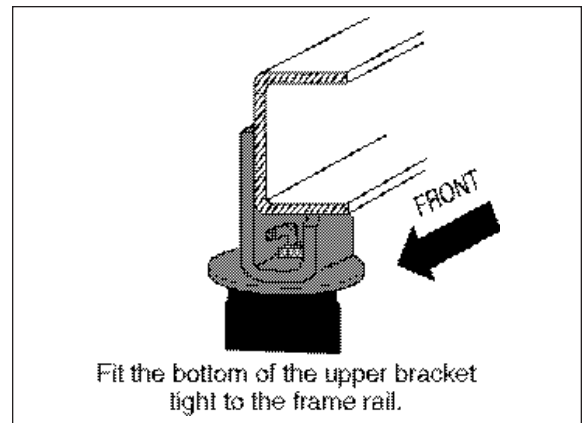

Figure 4

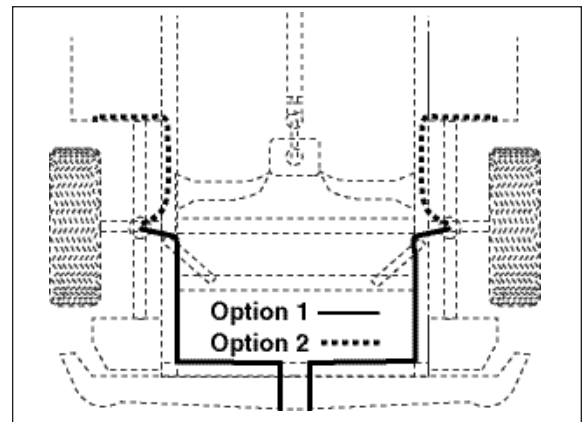

Figure 5

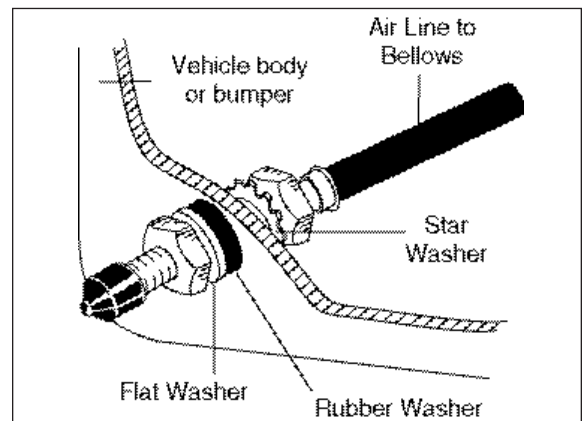

Figure 6

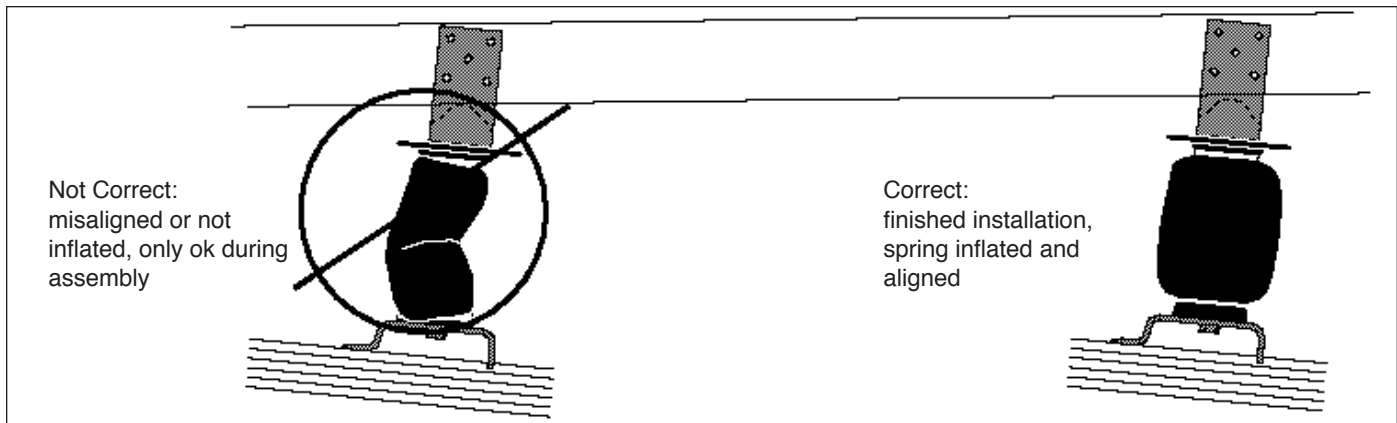

Figure 7

MINIMUM AIR PRESSURE	MAXIMUM AIR PRESSURE
5 p.s.i.	100 p.s.i.
<p><i>Failure to maintain correct minimum pressure (or pressure proportional to load), bottoming out, over-extension, or rubbing against another component will void the warranty.</i></p> <p><i>Regardless of load, the air pressure must always be adjusted so that the normal</i></p>	

Maintenance of the System

1. Check pressure weekly.
2. Always maintain at least 5 p.s.i. air pressure.
3. If you develop an air leak in the system, use a soapy water solution to check all air line connections and the inflation valve core before removing sleeve.

Operation of the System

1. Inflate your air springs to 60 p.s.i. before adding the payload. After vehicle is loaded, adjust your air pressure to level the vehicle.
2. **IMPORTANT:** For your safety and to prevent possible damage to your vehicle, do not exceed maximum load recommended by the vehicle manufacturer. Although your air springs are rated at maximum inflation pressure of 100 p.s.i., the air pressure actually needed is dependant on the load and Gross Vehicle Weight Rating (GVWR), which may be less than 100 p.s.i. Check your vehicle owner's manual and do not exceed maximum loads listed for your vehicle.
3. When inflating your Air Lift sleeves, add pressure in small quantities, check the pressure frequently during inflation. The sleeves require much less air volume than a tire and therefore inflate much faster.
4. Should it become necessary to raise the vehicle by the frame, make sure the system is at minimum pressure (5 p.s.i.) to reduce the tension on suspension/brake components. Check to see that the air spring rolls back down over the bottom piston after the vehicle is lowered (Figure 9). If sleeve fails to roll back down over the piston, add air pressure until sleeve pops back over piston (do not exceed 100 p.s.i.).



Thank you for purchasing Air Lift Products

Mailing Address:
AIR LIFT COMPANY
P.O. Box 80167
Lansing, MI 48908-0167

Street Address:
AIR LIFT COMPANY
2727 Snow Rd.
Lansing, MI 48917

Local Phone: (517) 322-2144
Fax: (517) 322-0240

For Technical Assistance call 1-800-248-0892

“The Choice of the Professional Installer”

Printed in the USA