

Please read these instructions completely before proceeding with installation

### Air Spring Kit Parts List

Item	Description	Quantity
A	Air Sleeve	2
B	Upper Bracket	2
C	Lower Bracket	2
D	Air Fitting	2
E	3/4" Nylon Nut	2
F	3/4" Star Washer	2
G	1/2" x 7/8" Hex Head Bolt	2
H	1/2" Flat Washer	2
I	3/8"-16 U-Bolt	2
J	3/8" Flat Washer	4
K	3/8" Nylock Nut	4
L	Clamp Bar	2
M	3/8" x 1" Self Tapping Bolt	2
AA	Air Line Assembly	1
BB	Tie Strap	6
CC	Valve Caps	2
DD	5/16" Flat Washer	2
EE	Rubber Washer	2
FF	Small Star Washer	2
GG	5/16" Hex Nut	4

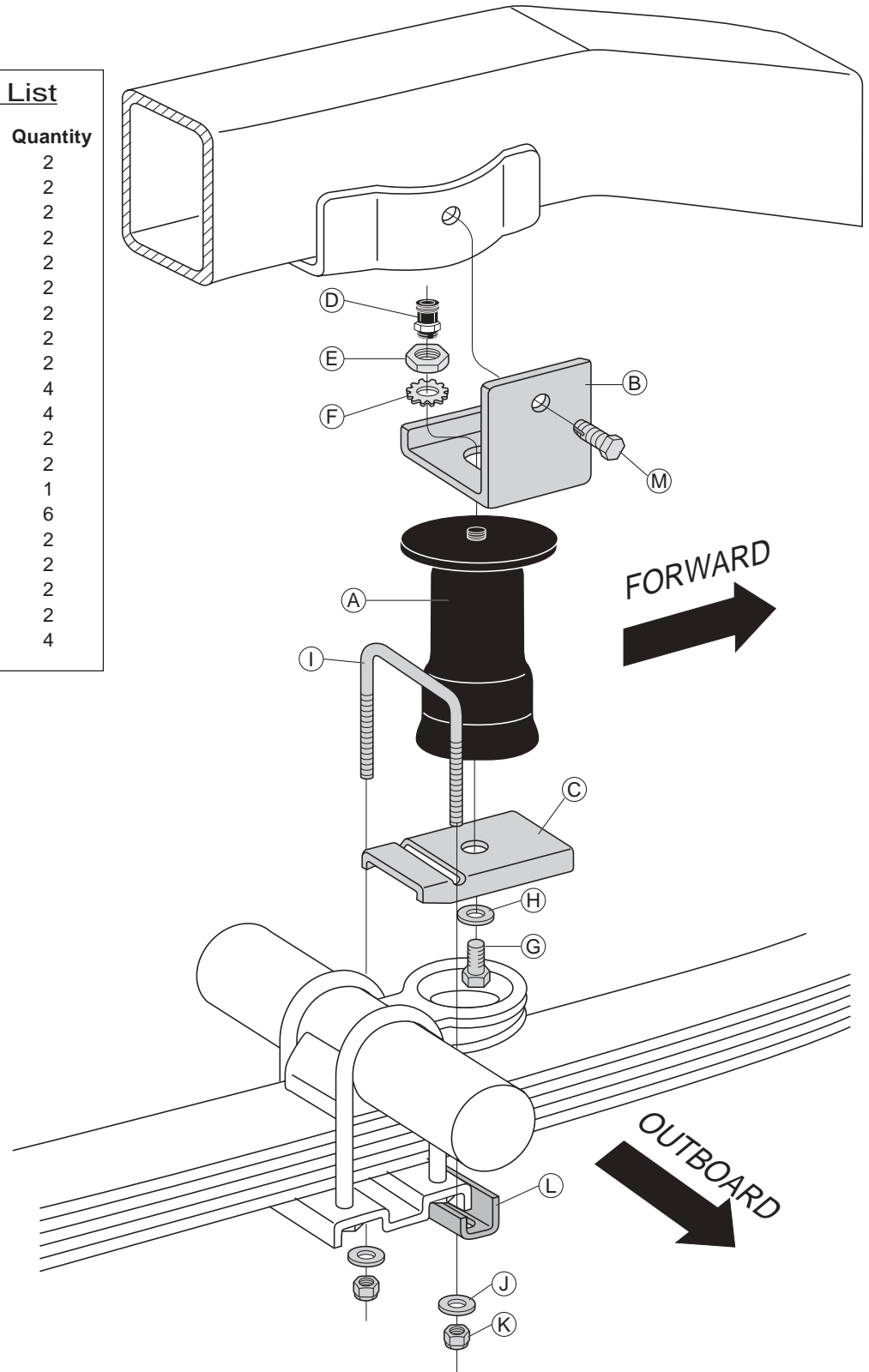

Figure 1

## Tools Needed

1/2", 9/16" open-end or box wrenches  
Crescent Wrench  
Ratchet with 9/16" and 1/2" deep well sockets  
5/16" drill bits (very sharp)  
Heavy Duty Drill  
Torque Wrench

Hose Cutter, Razor Blade, or Sharp Knife  
Hoist or Floor Jacks  
Safety Stands  
Safety Glasses  
Air Compressor, or Compressed Air Source  
Spray Bottle with Dish Soap/Water Solution

**IMPORTANT:** Your vehicle may be equipped with a rear brake proportioning valve. Any type of load assist product could affect brake performance. We recommend that you check with your dealer before installing this type of product. If your vehicle DOES NOT have a rear brake proportioning valve or is equipped with an anti-lock type brake system, installation of a load assist product will have NO EFFECT ON BRAKE SYSTEM PERFORMANCE.

**DANGER:** Compressed air can cause injury and damage to the vehicle and parts if it is not handled properly. For your safety, do not try to inflate the air springs until they have been properly secured to the vehicle.

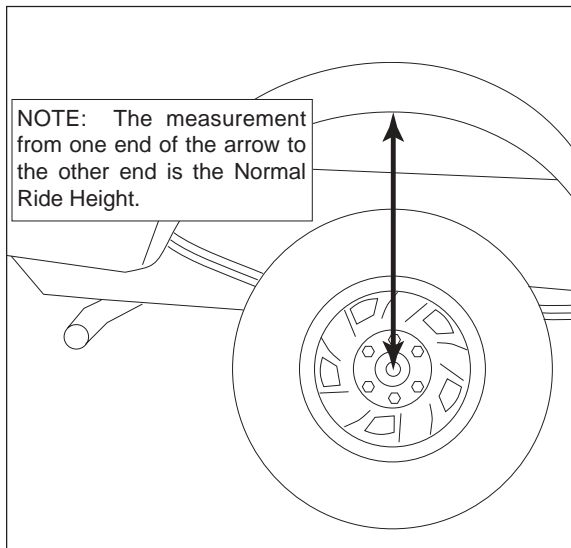

Figure 2

## I. Getting Started

1. Determine the Normal Ride Height. The Normal Ride Height is the distance between the bottom edge of the wheel-well and the center of the hub with the vehicle in the "as delivered" condition. In some cases, Normal Ride Height is not perfectly level.
  - a. Remove unusual loads and examine your vehicle from the side to ensure it is on a level surface.
  - b. If necessary (in cases where your leaf springs are sagging badly), use a jack to raise the rear end so that the vehicle achieves the original "as delivered" ride height.
2. Measure the distance between the center of the hub and the bottom edge of the wheel well (see Figure 2). This is the Normal Ride Height. Enter the measurement below:

NORMAL  
RIDE HEIGHT: \_\_\_\_\_ inches

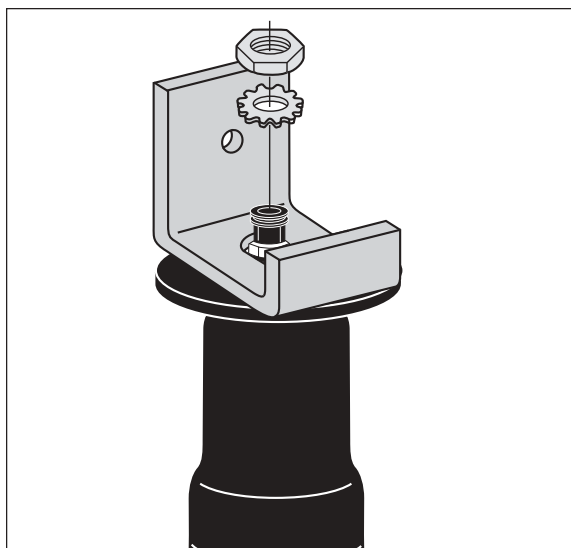

Figure 3

## II. Assembling the Air Spring Unit

1. Install the straight air fitting (D) to the top of the air spring (A). Tighten finger tight plus 1 and 1/2 turns (Figures 1 and 3).
2. Install upper bracket (B) to the top of the air spring by inserting the air fitting through the large slot on the bracket (Figures 1 and 3).
3. Install star washer (F) and nylon nut (E) over the air fitting in order to secure the upper bracket to the air spring. Leave loose at this time for later adjustment (Figures 1 and 3).

- Place U-bolt (I) on the top of the lower bracket (C) in the notched location and attach the lower bracket to the bottom of the spring using a hex bolt (G) and flat washer (H). Tighten to 15 ft-lbs (Figures 1 and 4).

### III. Attaching the Upper Bracket

- Remove the jounce bumper and jounce bumper cup from the frame.
- Set the assembly over the lower jounce bumper strike plate. Set in place so that the U-bolts straddle the leaf spring (Figure 5).
- Align the upper bracket on the frame so that the sleeve is parallel and perpendicular to the upper and lower brackets.
- Note and mark the area where the air fitting hits the bottom of the jounce bumper bracket. It is necessary to drill a hole through the bottom of the jounce bumper bracket in order to provide clearance for the air line.
- Remove the assembly and drill a  $\frac{9}{16}$ " hole in the previously marked location for the air line clearance.
- Set the assembly back in place and align the air spring in and out on the top so it is perpendicular to both brackets. When aligned at the top, carefully pull the upper bracket away from the frame and tighten the nylon nut (N) to 4 ft-lbs. *Do not overtighten. NOTE: It may be necessary to remove the assembly to tighten the top nut. Keep the top and bottom brackets aligned properly while doing this.*
- Using the hole in the upper bracket as a template, mark the upper jounce bumper bracket for the mounting location. Drill a  $\frac{5}{16}$ " hole. *NOTE: Be sure that the air line fitting is protected with a piece of tape so that the debris from drilling does not enter the air fitting. Not doing so will cause the fitting to fail.*  
*IMPORTANT: Make sure that the "J" touches the bottom of the jounce bumper bracket (Figure 6).*
- Set the upper bracket back in place on the frame and install a self tapping bolt (M). Refer to Figure 1. *Do not overtighten.*

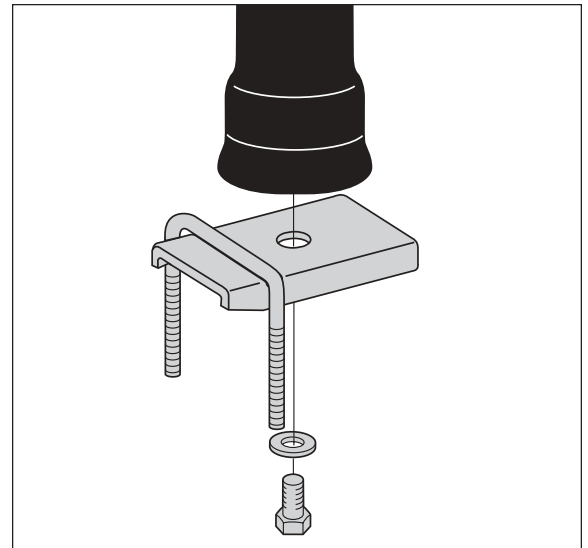

Figure 4

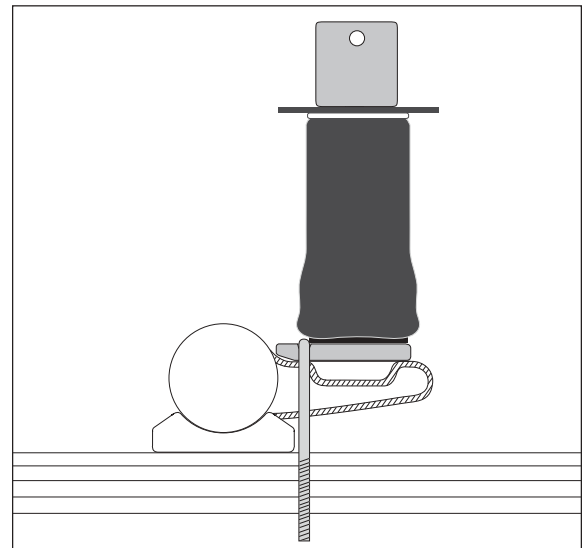

Figure 5

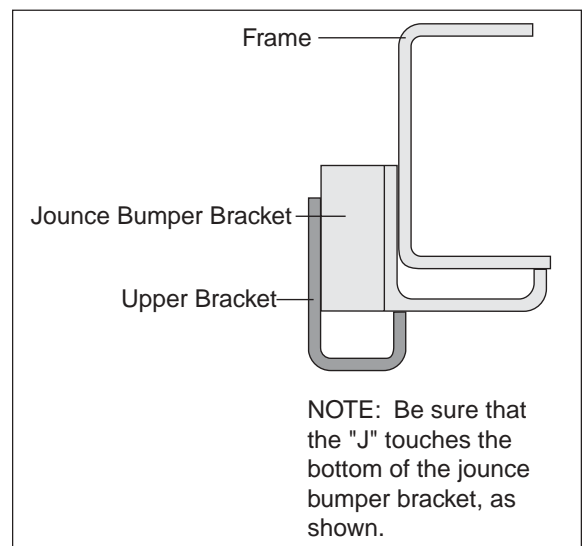

Figure 6

### IV. Attaching the Lower Bracket

- Insert the U-bolts into the holes in the clamp bar (L) and install the clamp bar so that the short end locks around the lower spring retainer (Figure 1).
- Attach the clamp bar (L) with two flat washers (J) and two nylock nuts (K). See Figure 1.
- Tighten the U-bolts securely.

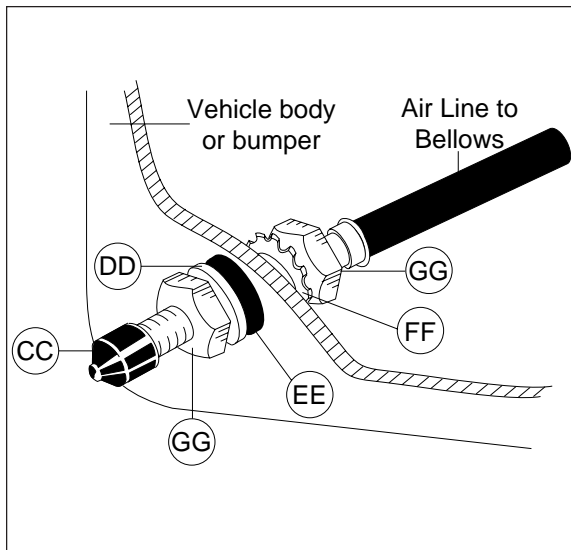

Figure 7

## V. Installing the Air Lines

1. Choose a convenient location for mounting the inflation valves. Popular locations for the inflation valve are: the wheel well flanges, the license plate recess in bumper, under the gas cap access door, or through license plate itself.

*NOTE: What ever the chosen location is, make sure there is enough clearance around the inflation valves for an air chuck.*

2. Drill a  $\frac{5}{16}$ " hole to install the inflation valves.
3. Cut the air line assembly (AA) in two equal lengths.

*CAUTION: When cutting or trimming the air line, use a hose cutter (Air Lift P/N 10530), a razor blade or a sharp knife. A clean, square cut will ensure against leaks. Do not use wire cutters or scissors to cut the air line. These tools may flatten or crimp the air line, causing it to leak around the O-ring seal inside the elbow fitting.*

4. Place a  $\frac{5}{16}$ " nut (GG) and a star washer (FF) on the air valve. Leave enough of the inflation valve in front of the nut to extend through the hole and have room for the rubber washer (EE), flat washer (DD), and  $\frac{5}{16}$ " nut (GG) and cap (CC). There should be enough valve exposed after installation - approximately  $\frac{1}{2}$ " - to easily apply a pressure gauge or an air chuck (Figure 7).
5. Push the inflation valve through the hole and use the rubber washer (EE), flat washer (DD), and another  $\frac{5}{16}$ " nut (GG) to secure it in place. Tighten the nuts to secure the assembly in place (Figure 7).
6. Route the air line along the frame to the air fitting on the air spring. Keep at least 6" of clearance between the air line and heat sources, such as the exhaust pipes, muffler, or catalytic converter. Avoid sharp bends and edges. Use the plastic tie straps (BB) to secure the air line to fixed, non-moving points along the chassis. Be sure that the tie straps are tight, but do not pinch the air line. Leave at least 2" of slack to allow for any movement that might pull on the air line.
7. Cut off air line leaving approximately 12" of extra air line. A clean square cut will ensure against leaks. Insert the air line into the air fitting. This is a push to connect fitting. Simply push the air line into the air fitting until it bottoms out ( $\frac{9}{16}$ " of air line should be in the fitting).
8. Repeat entire installation procedure for the remaining side.

## VI. Checking for Leaks

1. Inflate the air spring to 30 p.s.i.
2. Spray all connections and the inflation valves with a solution of  $\frac{1}{5}$  liquid dish soap and  $\frac{4}{5}$  water to check for leaks (Figure 24). You should be able to spot leaks easily by looking for bubbles in the soapy water.
3. After the test, deflate the springs to the minimum pressure required to restore the Normal Ride Height, but not less than 5 p.s.i.
4. **IMPORTANT:** Check the air pressure again after 24 hours. A 2 to 4 p.s.i. loss after initial installation is normal. Retest for leaks if the loss is more than 5 lbs.

## VII. Fixing Leaks

1. If there is a problem with the swivel fitting, then:
  - a. Check the air line connection by deflating the spring and removing the line by pulling the collar against the fitting and pulling firmly on the air line. Trim 1" off the end of the air line. Be sure the cut is clean and square. Reinsert the air line into the push-to-connect fitting.
  - b. Check the threaded connection by tightening the swivel fitting another  $\frac{1}{2}$  turn. If it still leaks, deflate the air spring, remove the fitting, and re-coat the threads with thread sealant. Reinstall by hand tightening as much as possible, then use a wrench for an additional two turns.
2. If there is a problem with the inflation valve, then:
  - a. Check the valve core by tightening it with a valve core tool.
  - b. Check the air line connection by removing the air line from the barbed type fitting. *CAUTION: Do not cut it off. As this will usually nick the barb and render the fitting useless.* Cut air line off a few inches in front of the fitting and use a pair of pliers or vise-grips to pull/twist the air line off the fitting.
3. If the preceding steps have not resolved the problem, call Air Lift Technical Service at 1-800-248-0892 for assistance.

## VIII. Troubleshooting Guide

*Problems maintaining air pressure, without on-board compressor.*

1. Leak test the air line connections and threaded connection of the elbow into the air spring. See Section VII to repair.
2. Leak test the inflation valve for leaks at the air line connection or dirt or debris in the valve core. See Section VII for repair.
3. Inspect air lines to be sure it is not pinched. Tie straps may be too tight. Loosen or replace strap. Replace leaking components.
4. Inspect air line for holes and cracks. Replace as needed.
5. A kink or fold in the air line. Reroute as needed.

*You have now tested for all of the most probable leak conditions that can be easily fixed. At this point the problem is most likely a failed air spring - either a factory defect or an operating problem. Please call Air Lift at 1-800-248-0892 for assistance or a replacement air spring.*

## IX. Checklist

You can protect your warranty on this product and prevent unnecessary wear by ensuring the following checks have been made:

### Section I – Installation (To be completed by the installer):

- 1. Clearance Test - Inflate the air springs to 60 p.s.i. and ensure there is at least 1/2 " clearance around each sleeve from anything that might rub against them. Be sure to check the tire, brake drum, frame, shock absorbers and brake cables.
- 2. Leak Test Before Road Test – Inflate the air springs to 60 p.s.i., check all connections for leaks with a soapy water solution. See page 5 of the manual for tips on how to spot leaks. All leaks must be eliminated before the vehicle is road tested.
- 3. Heat Test – Be sure there is sufficient clearance from heat sources - at least 6" for air springs and air lines. If a heat shield was included in the kit - install it. If there is no heat shield, but one is required, call 1-800-248-0892.
- 4. Fastener Test – Recheck all bolts for proper torque.

Torque Guide:

<sup>3</sup> / <sub>8</sub> " Frame Bolts	16 ft-lbs
U-bolt Lock Nuts	16 ft-lbs

- 5. Road Test – The vehicle should be road tested after the preceding tests. Inflate the springs to 25 p.s.i. (50 p.s.i. if vehicle is loaded). Drive the vehicle 10 miles and recheck for clearance, loose fasteners and/or air leaks.
- 6. Operating Instructions – If professionally installed, the installer should review the operating instructions on page 7 with the owner. Be sure to provide the owner with all of the paperwork that came with the kit.

### Section II - Post Installation Checklist (To be completed by the owner):

- 1. Overnight Leakdown Test – Recheck air pressure after vehicle has been used for 24 hours. If pressure has dropped more than 5 p.s.i. then, you have a leak that must be fixed. Either fix the leak yourself (see page 5) or return to the installer for service.
- 2. Air Pressure Requirements – I understand that the air pressure requirements of my air spring system are as follows:

Minimum \_\_\_\_\_ Maximum \_\_\_\_\_

I also understand that I must inflate the air springs until the Ride Height measurement that was recorded on page 2 has been restored. Regardless of load, the air pressure should always be adjusted so that the Ride Height is maintained at all times.

- 3. Thirty Day or 500 Mile Test. I understand that I must recheck the air spring system after 30 days or 500 miles, whichever comes first. If any part shows signs of rubbing or abrasion, the source should be identified and moved, if possible. If it is not possible to relocate the cause of the abrasion, the air spring may need to be remounted. If professionally installed, the installer should be consulted. Check all fasteners for tightness.

## X. Maintenance and Operations

Minimum Air Pressure	Maximum Air Pressure
5 p.s.i.	100 p.s.i.
<i>Failure to maintain correct minimum pressure (or pressure proportional to load), bottoming out, over-extension, or rubbing against another component will void the warranty.</i>	

By following these steps, vehicle owners will obtain the longest life and best results from their air springs.

1. Check the air pressure weekly.
2. Always maintain Normal Ride Height. Never inflate beyond 100 p.s.i.
3. If you develop an air leak in the system, use a soapy water solution to check all air line connections and the inflation valve core before deflating and removing the air spring.
4. When increasing load, always adjust the air pressure to maintain the Normal Ride Height. Increase or decrease pressure from the system as necessary to attain Normal Ride Height for optimal ride and handling. Remember that loads carried behind the axle (including tongue loads) require more leveling force (pressure) than those carried directly over the axle.
5. **IMPORTANT:** For your safety and to prevent possible damage to your vehicle, *do not exceed maximum Gross Vehicle Weight Rating (GVWR), as indicated by the vehicle manufacturer.* Although your air springs are rated at a maximum inflation pressure of 100 p.s.i. The air pressure actually needed is dependant on your load and GVWR, which may be less than 100 p.s.i. Check your vehicle owners manual and do not exceed the maximum load listed for your vehicle.
6. Always add air to springs in small quantities, checking the pressure frequently. Sleeves require less air volume than a tire and inflate quickly.
7. *Should it become necessary to raise the vehicle by the frame, make sure the system is at minimum pressure (5 p.s.i.) to reduce the tension on the suspension/brake components. Use of on-board leveling systems do not require deflation or disconnection.*



***Thank you for purchasing Air Lift Products***

Mailing Address:  
AIR LIFT COMPANY  
P.O. Box 80167  
Lansing, MI 48908-0167

Street Address:  
AIR LIFT COMPANY  
2727 Snow Rd.  
Lansing, MI 48917

Local Phone: (517) 322-2144

Fax: (517) 322-0240

[www.airliftcompany.com](http://www.airliftcompany.com)

For Technical Assistance call 1-800-248-0892

***“The Choice of the Professional Installer”***

Printed in the USA



# Product Use Information

## Frequently asked questions

**Q. Will installing air springs increase the weight ratings of a vehicle?**

No. Adding air springs will not change the weight ratings (GAWR, GCWR and/or GVWR) of a vehicle. Exceeding the GVWR is dangerous and voids the Air Lift warranty.

**Q. Is it necessary to keep air in the air springs at all time and how much pressure will they need?**

The minimum air pressure should be maintained at all times. The minimum air pressure keeps the air spring in shape, ensuring that it will move throughout its travel without rubbing or wearing on itself.

**Q. Is it necessary to add a compressor system to the air springs?**

No. Air pressure can be adjusted with any type of compressor as long as it can produce sufficient pressure to service the springs. Even a bicycle tire pump can be used, but it's a lot of work.

**Q. How long should air springs last?**

If the air springs are properly installed and maintained they can last indefinitely.

**Q. Will raising the vehicle on a hoist for service work damage the air springs?**

No. The vehicle can be lifted on a hoist for short-term service work such as tire rotation or an oil changes. However, if the vehicle will be on the hoist for a prolonged period of time, support the axle with jack stands in order to take the tension off of the air springs.

## Tuning the air pressure

Pressure determination comes down to three things — level vehicle, ride comfort, and stability.

**1. Level vehicle**

If the vehicle's headlights are shining into the trees or the vehicle is leaning to one side, then it is not level (fig. 1). Raise the air pressure to correct either of these problems and level the vehicle.

**2. Ride comfort**

If the vehicle has a rough and harsh ride it may be due to either too much pressure or not enough. Try different pressures to determine the best ride comfort.

**3. Stability**

Stability translates into safety and should be the priority, meaning the driver may need to sacrifice a perfectly level and comfortable ride. Stability issues include roll control, bounce, dive during braking and sponginess (fig. 2). Tuning out these problems usually requires an increase in pressure.

fig. 1

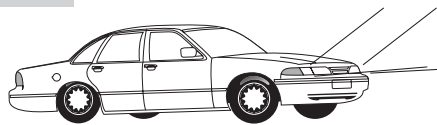

Bad headlight aim

fig. 2

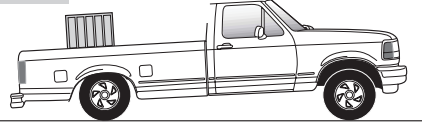

Unlevel, bottoming out

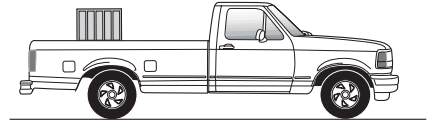

Level

### Guidelines for adding air:

1. Start with the vehicle level or slightly above.
2. When in doubt, always add air.
3. For motorhomes, start with 50-100 p.s.i. in the rear because it can be safely assumed that it is heavily loaded.
4. If the front of the vehicle dives while braking, increase the pressure in the front air bags, if equipped.
5. If it is ever suspected that the air bags have bottomed out, increase the pressure (fig. 3).
6. Adjust the pressure up and down to find the best ride.
7. If the vehicle rocks and rolls, adjust the air pressure up and down to reduce the rocking and rolling.
8. It may be necessary to maintain different pressures on each side of the vehicle. Loads such as water, fuel, and appliances will cause the vehicle to be heavier on one side (fig. 4). As much as a 50 p.s.i. difference is not uncommon.

*fig. 3*

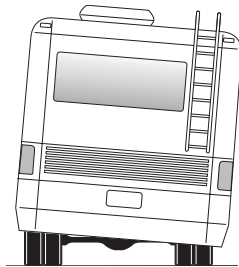

Poor stability

*fig. 4*

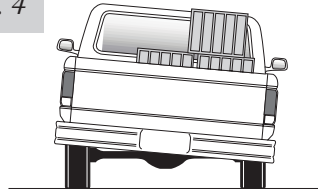

Unlevel

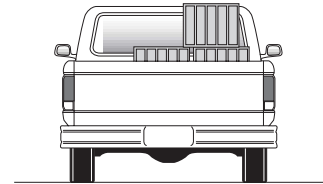

Level