

# LoadLIFTER 5000

by AIR LIFT®

## Kit 57394

*Ford F-250, F-350*  
*Underframe*

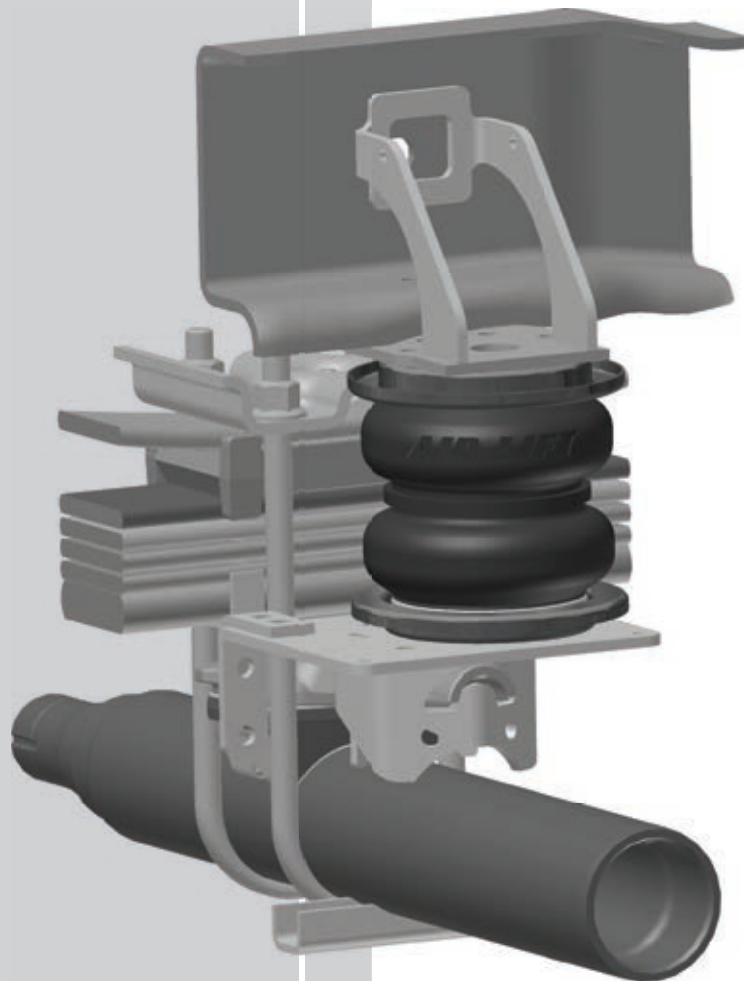

## INSTALLATION GUIDE

For maximum effectiveness and safety, please read these instructions completely before proceeding with installation.

*Failure to read these instructions can result in an incorrect installation.*



# TABLE OF CONTENTS

<b>Introduction</b> . . . . .	<b>2</b>
Important Safety Notice . . . . .	2
Notation Explanation . . . . .	2
<b>Installation Diagram</b> . . . . .	<b>3</b>
Hardware List . . . . .	6
Tools List . . . . .	6
<b>Installing the LoadLifter 5000 System</b> . . . . .	<b>6</b>
Getting Started . . . . .	6
Installing the Upper Bracket . . . . .	7
Lower Bellows and Bracket Assembly . . . . .	8
Positioning the Assembly on the Axle . . . . .	9
Bolting Down the Assembly . . . . .	9
Lower Bracket Attachment . . . . .	10
2WD DRW Models . . . . .	11
Final Steps . . . . .	12
Installing the Air Lines . . . . .	12
Installing the Heat Shield . . . . .	14
Checking for Leaks . . . . .	14
Fixing Leaks . . . . .	14
<b>Before Operating</b> . . . . .	<b>15</b>
Installation Checklist . . . . .	15
Post-Installation Checklist . . . . .	15
<b>Maintenance and Operations</b> . . . . .	<b>16</b>
Maintenance Guidelines . . . . .	16
<b>Product Use</b> . . . . .	<b>17</b>
Frequently Asked Questions . . . . .	17
Tuning the Air Pressure . . . . .	17
Guidelines for Adding Air . . . . .	18
<b>Warranty and Return Policy</b> . . . . .	<b>19</b>
<b>Replacement and Contact Information</b> . . . . .	<b>20</b>

# Introduction

The purpose of this publication is to assist with the installation, maintenance and troubleshooting of the LoadLifter 5000 air spring kit. LoadLifter 5000 utilizes sturdy, reinforced, commercial grade single or double, depending on the kit, convolute bellows. The bellows are manufactured like a tire with layers of rubber and cords that control growth. LoadLifter 5000 kits are recommended for most  $\frac{3}{4}$  and 1 ton pickups and SUVs with leaf springs and provide up to 5,000 lbs of load leveling support with air adjustability from 5-100 p.s.i. The kits are also used in motorhome rear kits and some motorhome fronts where leaf springs are used.

It is important to read and understand the entire installation guide before beginning installation or performing any maintenance, service or repair. The information here includes a hardware list, tool list, step-by-step installation information, maintenance tips, safety information and a troubleshooting guide.

Air Lift Company reserves the right to make changes and improvements to its products and publications at any time. For the latest version of this manual, contact Air Lift Company at (800) 248-0892 or visit our website at [www.airliftcompany.com](http://www.airliftcompany.com).

## IMPORTANT SAFETY NOTICE

The installation of this kit does not alter the Gross Vehicle Weight Rating (GVWR) or payload of the vehicle. Check your vehicle's owner's manual and do not exceed the maximum load listed for your vehicle.

**Gross Vehicle Weight Rating:** The maximum allowable weight of the fully loaded vehicle (including passengers and cargo). This number — along with other weight limits, as well as tire, rim size and inflation pressure data — is shown on the vehicle's Safety Compliance Certification Label.

**Payload:** The combined, maximum allowable weight of cargo and passengers that the truck is designed to carry. Payload is GVWR minus the Base Curb Weight.

## NOTATION EXPLANATION

Hazard notations appear in various locations in this publication. Information which is highlighted by one of these notations must be observed to help minimize risk of personal injury or possible improper installation which may render the vehicle unsafe. Notes are used to help emphasize areas of procedural importance and provide helpful suggestions. The following definitions explain the use of these notations as they appear throughout this guide.

### DANGER

INDICATES IMMEDIATE HAZARDS WHICH WILL RESULT IN SEVERE PERSONAL INJURY OR DEATH.

### WARNING

INDICATES HAZARDS OR UNSAFE PRACTICES WHICH COULD RESULT IN SEVERE PERSONAL INJURY OR DEATH.

### CAUTION

INDICATES HAZARDS OR UNSAFE PRACTICES WHICH COULD RESULT IN DAMAGE TO THE MACHINE OR MINOR PERSONAL INJURY.

## NOTE

*Indicates a procedure, practice or hint which is important to highlight.*

# Installation Diagram

4 X 4 Model,  
Driver's side shown

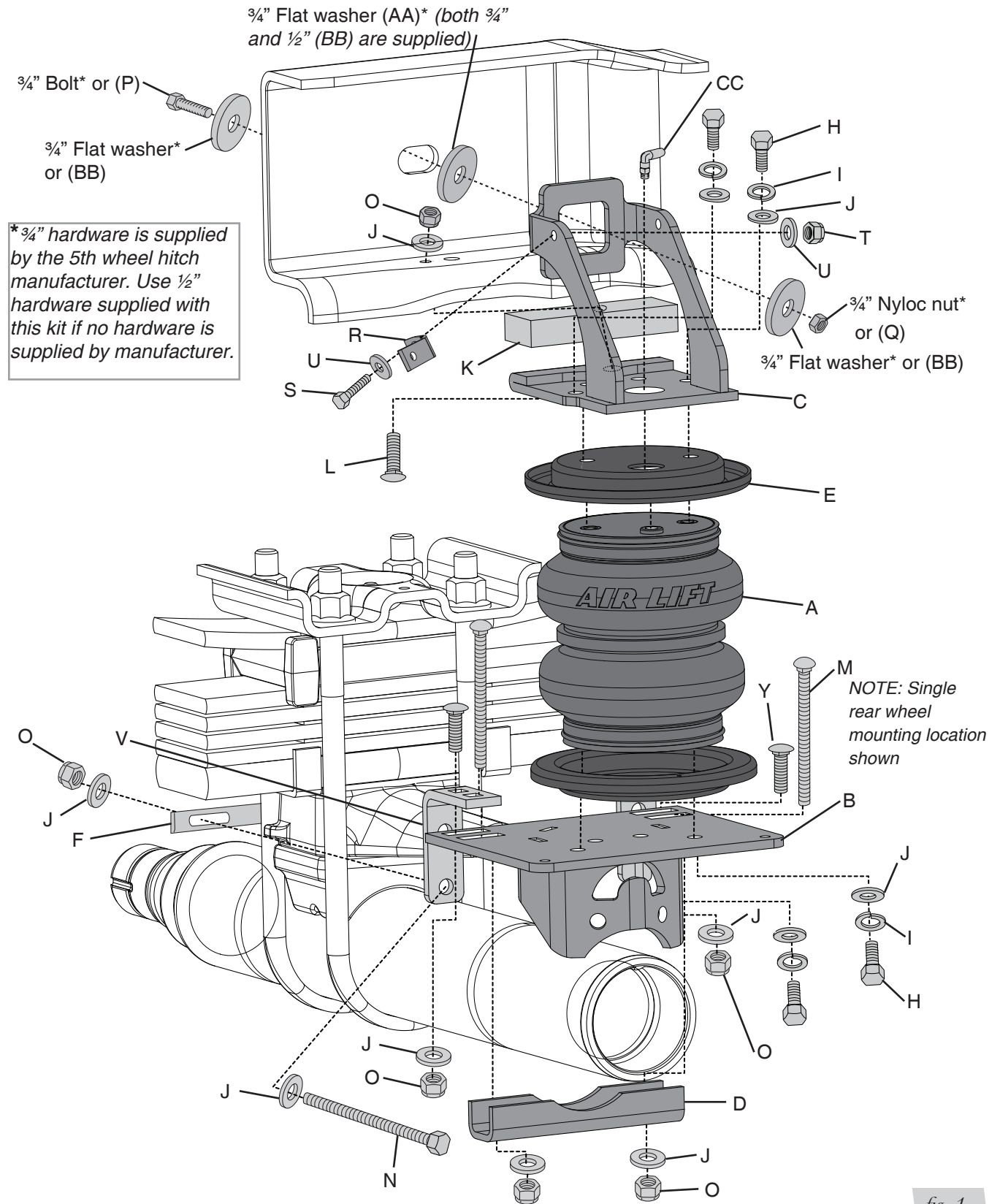

fig. 1

# Installation Diagram

**2 X 4, 3 1/2" Axle model,  
Driver's side shown  
(Single rear wheel model only)**

3/4" Flat washer (AA)\* (both 3/4" and 1/2" (BB) are supplied)

3/4" Bolt\* or (P)

3/4" Flat washer\* or (BB)

*\*3/4" hardware is supplied by the 5th wheel hitch manufacturer. Use 1/2" hardware supplied with this kit if no hardware is supplied by manufacturer.*

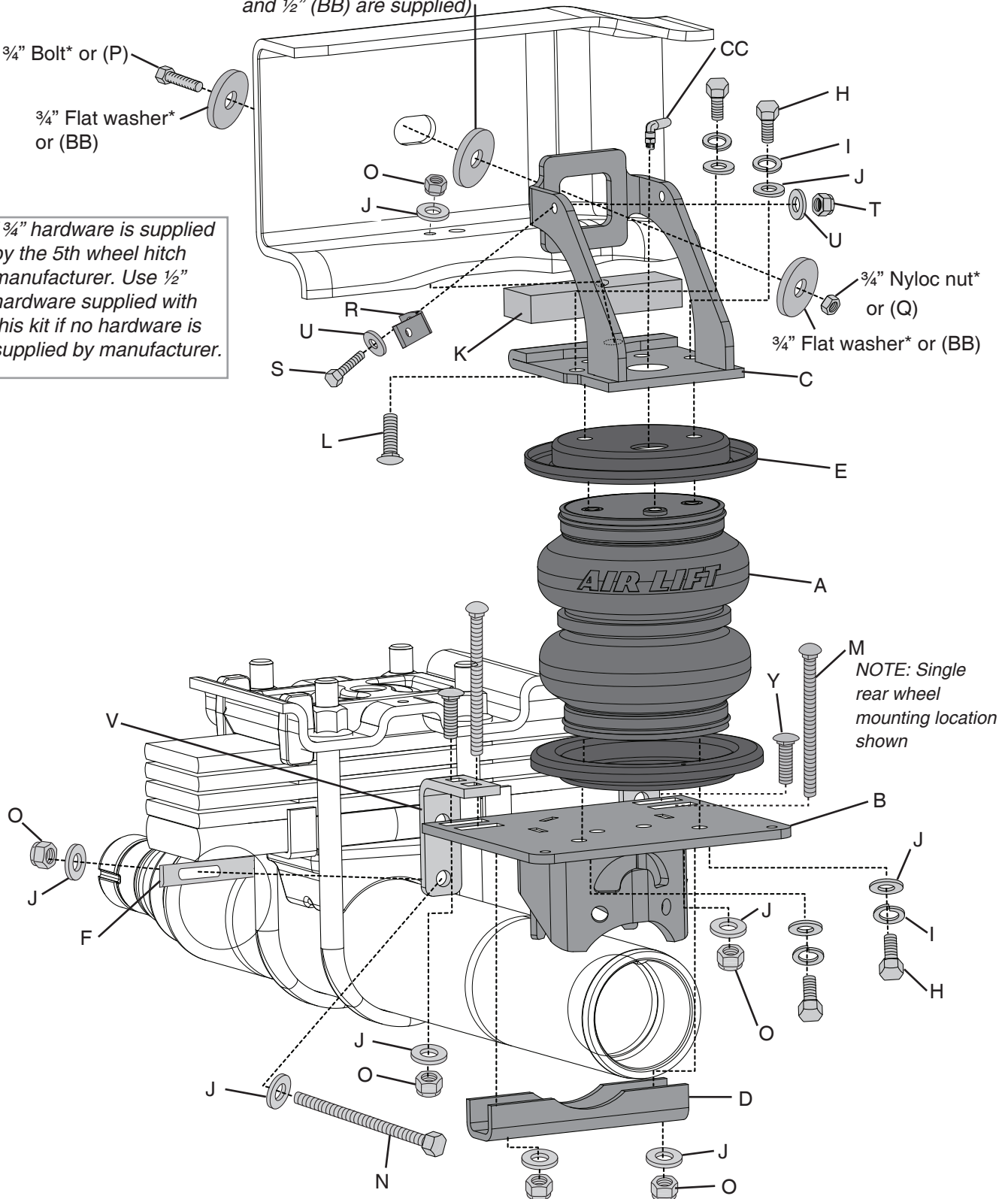

**NOTE: Single rear wheel mounting location shown**

*fig. 2*

# Installation Diagram

2 X 4, 4" Axle model,  
Driver's side shown  
(Dual rear wheel model only)

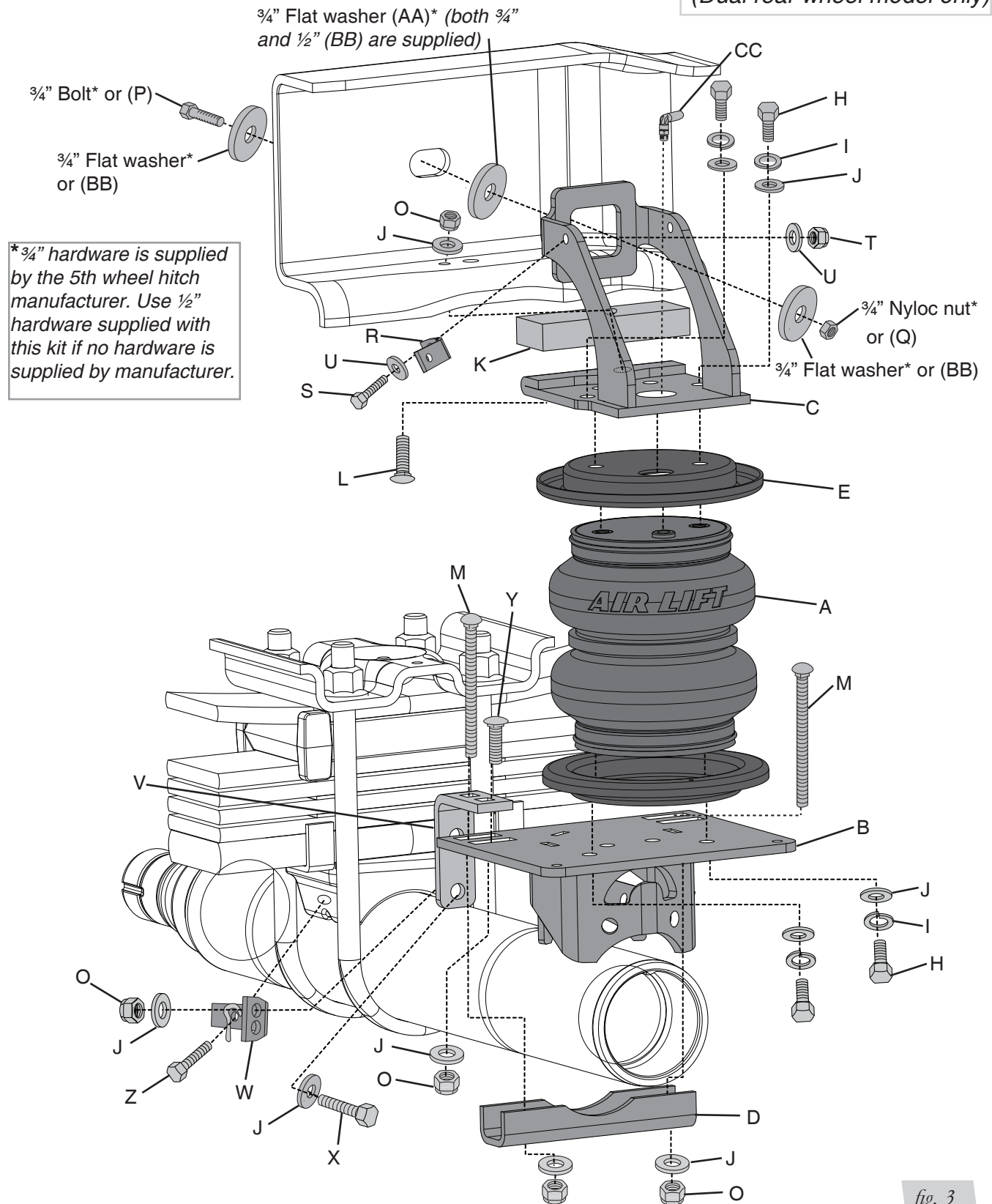

fig. 3

## HARDWARE LIST

Item	Part #	Description.....Qty	Item	Part #	Description.....Qty
A	58437	Bellows.....2	T	18425	1/4"-20 Nyloc nut.....1
B	03106	Lower bracket .....2	U	18419	Flat washer #12 .....2
C	07148	Upper bracket .....2	V	10880	Four hole locating bracket.....4
D	01531	Axle clamp bar .....2	W	10889	Three hole locating bracket.....2
E	11951	Roll plate .....4	X	17188	3/8"-16 x 1.25 Hex head cap screw ....2
F	10861	Spring clamp bar.....2	Y	17361	3/8"-16 x 1.25 Carriage bolt .....4
H	17203	3/8"-24 x 7/8 Bolt.....8	Z	17388	M8 - 1.25 x 16 Hex head cap screw ...2
I	18427	3/8" Lock washer.....8	AA	18556	3/4" x 2 Flat washer .....2
J	18444	3/8" Flat washer .....30	BB	18207	1/2" Thick flat washer.....6
K	13966	Spacer.....2	CC	21837	90° Swivel elbow fitting .....2
L	17141	3/8"-16 x 2.5 Carriage bolt .....2	*AAA	20086	Air line assembly.....1
M	17387	3/8"-16 x 10 Carriage bolt .....4	*BBB	10466	Tie strap .....6
N	17110	3/8"-16 x 5.5 Hex head cap screw .....4	*CCC	21230	Valve caps .....2
O	18435	3/8"-16 Nyloc nut.....14	*DDD	18405	5/16" Flat washer .....2
P	17271	1/2"-13 x 3 Hex head cap screw .....2	*EEE	21234	Rubber washer.....2
Q	18460	1/2"-13 Nyloc nut.....2	*FFF	18411	Small star washer .....2
R	10866	L bracket .....1	*GGG	21233	5/16" Hex nut .....4
S	17135	1/4"-20 x 1 Hex head cap screw .....1	*HHH	34365	Heat shield.....1
T	18425	1/4"-20 Nyloc nut.....1			

\*Not shown in figs. 1, 2 or 3.



Missing or damaged parts? Call Air Lift customer service at (800) 248-0892 for a replacement part.

## TOOLS LIST

Description..... Qty	Description..... Qty
7/16" and 9/16" Open-end or box wrenches..... 2	Standard, metric and SAE sockets and wrenches ..... 1
Crescent wrench..... 1	Hose cutter, razor blade, or sharp knife ..... 1
Ratchet with 3/8", 9/16", & 1/2" deep well sockets..... 1	Hoist or floor jacks ..... 1
5/16" drill bits (very sharp)..... 1	Safety stands..... 1
DIR grinder ..... 1	Safety glasses..... 1
Hacksaw ..... 1	Air compressor or compressed air source..... 1
Heavy duty drill ..... 1	Spray bottle with dish soap/water solution ..... 1
Torque wrench..... 1	

# Installing the LoadLifter 5000 System

## GETTING STARTED

1. Raise the vehicle and support the axle with jack stands, setting the jack stands as wide as possible on the axle.
2. Remove the jounce bumpers from under the frame, over the axle.
3. If necessary, disconnect the wiring harness from the driver side frame rail to gain clearance for the upper bracket.

### NOTE

*Some models have emission lines on the inside of the frame. Follow the directions in the section, "Installing the Upper Bracket," for relocating these lines.*

4. For all dual rear wheel vehicles (DRW) it will be necessary to remove the sway bar strap and bolts holding the sway bar to the axle. Retain for later reinstallation.
5. If you have a fifth wheel hitch already installed, it will be necessary to remove the 3/4" hardware that bolts the side bracket to the outside of the frame above the axle (fig. 4).



**NOTE**

Some hitch models have a spacer between the bracket and the frame rail. Be sure to reinstall the spacer when attaching the upper bracket.

**INSTALLING THE UPPER BRACKET**

1. Insert a 3/8" carriage bolt (L) through the bottom of the upper bracket (C) (fig. 4). Set the spacer (K) over the carriage bolt.

**NOTE**

The hole in the flat spacer (K) is offset. Install the spacer so that the wide portion faces the outside of the vehicle.

**NOTE**

If your model truck has emission lines running along the inside of the frame rail (fig. 5), it will be necessary to relocate those lines as follows:

- Carefully push the line holder out of the frame above the axle. Try to minimize damage because it will be reused later. It may also be helpful to remove any holders forward or rearward of the axle to aid in positioning the lines once the upper bracket has been installed (fig. 5).
- Attach the L-bracket (R) to the back frame brace using the 1/4" bolt (S), flat washers (U) and nyloc nut (T) supplied (fig. 4). This L-bracket will eventually be used to attach the previously removed emissions line. Do not attach the line holder to it at this time.

2. While positioning the upper bracket into the frame rail, insert the carriage bolt through the existing jounce bumper hole (fig. 4).

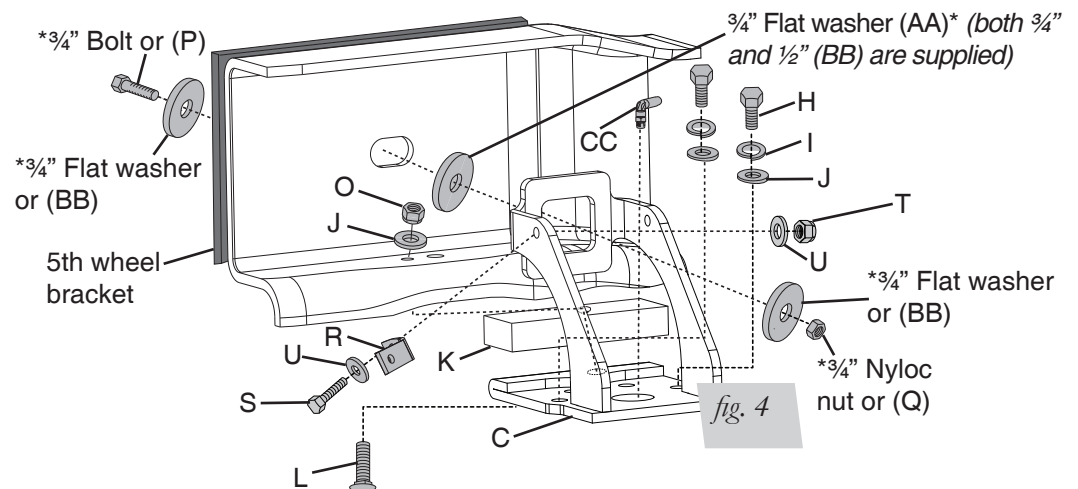

\*3/4" hardware is supplied by the 5th wheel hitch manufacturer. Use 1/2" hardware supplied with this kit if no hardware is supplied by manufacturer.

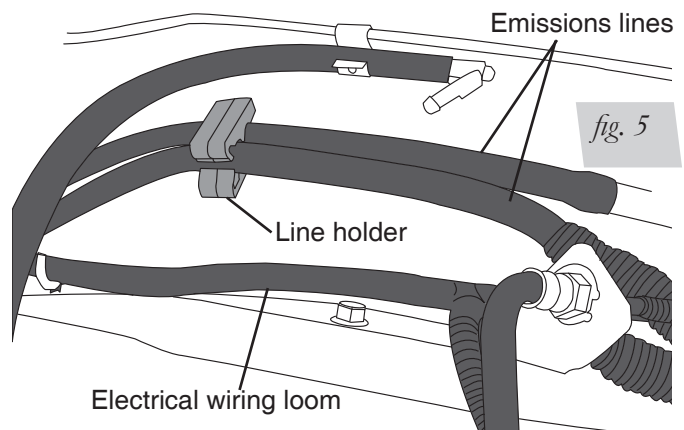

3. Cap with a 3/8" flat washer (J) and nyloc nut (O) (fig. 4). Do not tighten at this time.

## CAUTION

BE SURE NOT TO PINCH THE PREVIOUSLY MOVED WIRING OR LINES INSIDE THE LEFT FRAME RAIL.

## NOTE

If your 5th wheel hitch model does not come with holes through the side bracket for attaching the kit to the frame, it will be necessary to drill a hole and use the 1/2" hardware supplied to attach the upper bracket to the frame.

- Push the upper bracket up and against the inside frame rail. Mark and center punch the 5th wheel bracket that is on the outside of the frame through the hole in the upper bracket and slot in the frame.
- Drill a 1/2" hole through the 5th wheel bracket.

## LOWER BELLOWS AND BRACKET ASSEMBLY

1. Set a roll plate over the top and bottom of the bellows (A) (fig. 1).

## NOTE

The radiused (rounded) edge of the roll plate (E) will be towards the bellows so that the bellows is seated inside both roll plates (fig. 1).

### 2WD Models

- 2a. Proceed to step 4.

### 4WD Models

- 2b. It will be necessary to break off the curved leg that is tack welded to the lower bracket.
3. Clamp the bracket in a vise or set the bracket on the ground and hit the curved leg with a hammer, breaking it off (fig. 6). Grind or file the weld flush to the lower bracket and discard the curved leg.
4. The lower bracket (B) has two sets of holes (fig. 7). Attach the bellows to the bracket using the 3/8" flat washers (J), lock washers (I) and 3/8"-24 x 7/8 bolts (H) using the corresponding holes designated. Tighten bolts securely.

## NOTE

The insert for the fitting on top of the bellows points inward (refer to fig. 1 - fig. 3).

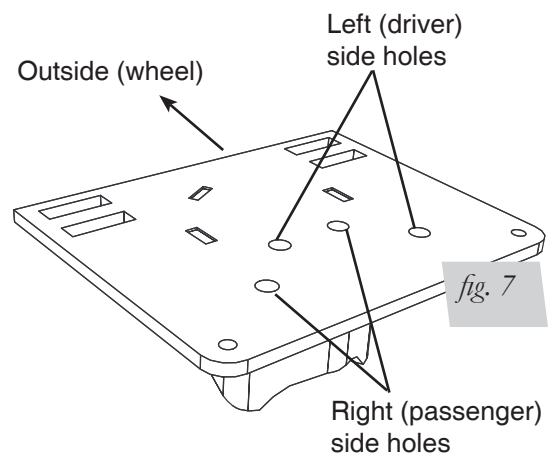
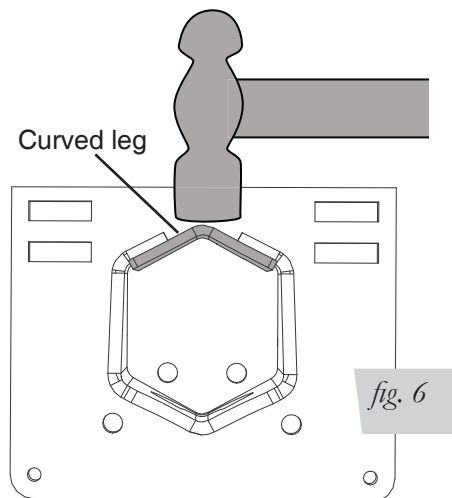

## POSITIONING THE ASSEMBLY ON THE AXLE

### 2WD Models

1a. Set the assembly on the axle below the upper bracket (fig. 2 or 3)

### 4WD Models

1b. Insert the left hand jounce bumper strike plate into the left hand lower assembly (fig. 8).

### NOTE

*It may be necessary to support the frame and lower the axle to gain clearance for the air spring assembly.*

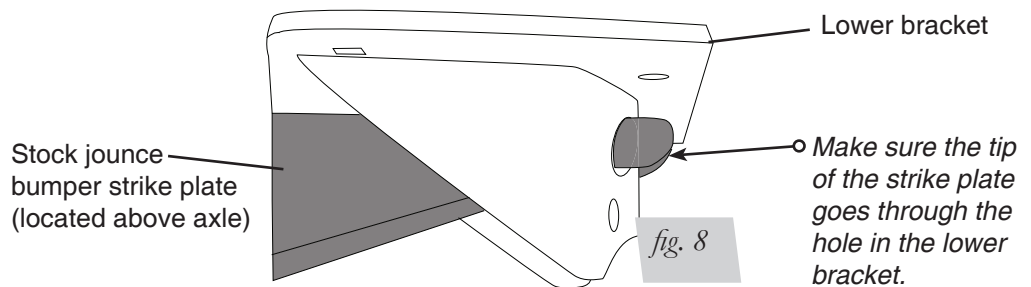

2. Attach the bellows to the loose upper bracket using 3/8" flat washers (J), lock washers (I) and 3/8"-24 x 7/8 bolts (H) using the corresponding holes in the upper bracket (fig. 9). Tighten both mounting bolts securely.

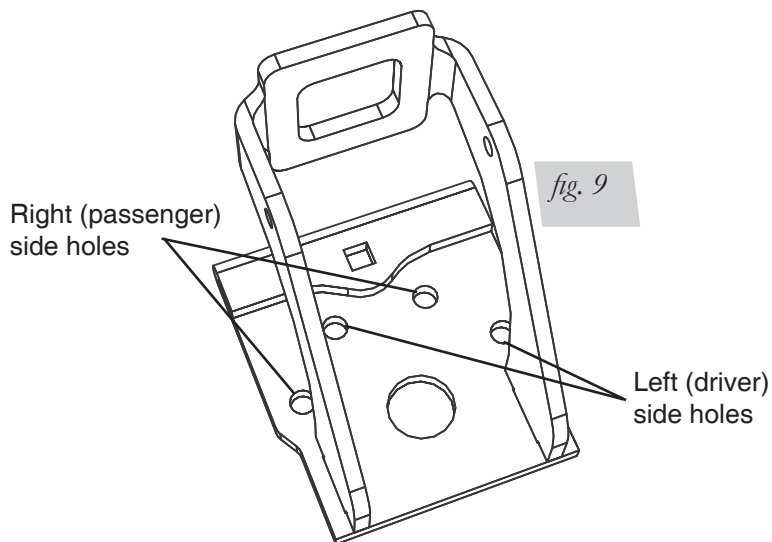

## BOLTING DOWN THE ASSEMBLY

1. With the bellows attached to the upper bracket, tighten the carriage bolt that goes through the upper bracket and into the frame (fig. 4).
2. Check the inside upper bracket to frame clearance. If there is a gap between the brace and frame, or the upper bracket is not parallel to the frame flange, add a large 1/2" (BB) or 3/4" flat washer (AA) between the frame and brace (fig. 4).
3. Attach the upper bracket brace to the frame using the existing hardware from the fifth wheel bracket installation that was previously removed or the 1/2" bolt (P), flat washers (BB) and nyloc nuts (Q) provided. Tighten securely (fig. 4).



**CAUTION**

**BE SURE TO NOT PINCH THE WIRING HARNESS OR LINES INSIDE OF THE LEFT FRAME RAIL.**

4. Repeat for the other side of the vehicle.

5. If so equipped with the emissions line previously loosened from the frame, insert the line holder post into the L-bracket (R) attached to the back brace of the upper bracket (C) (fig. 10). It may be necessary to move the line holder post forward or back on the lines to line up correctly with the L-bracket hole. Reattach any line holders removed forward or behind the axle, if possible, that were removed to aid in positioning the upper bracket.
6. Raise the axle (if it was previously lowered) and push the lower bracket against the leaf spring u-bolts.

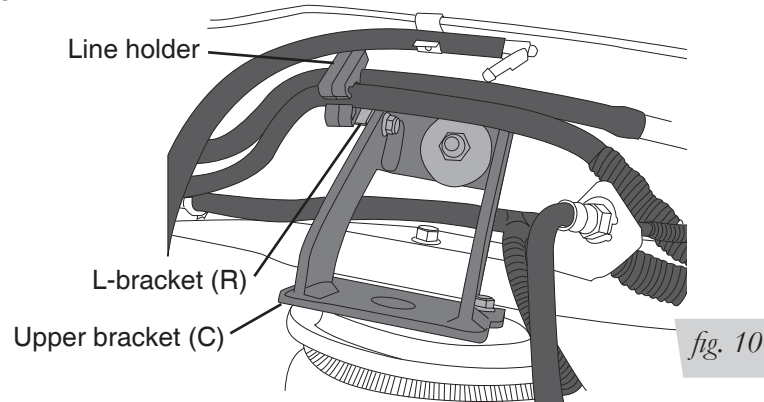

## LOWER BRACKET ATTACHMENT

### CAUTION

ATTACHING THE LOWER BRACKET WILL DEPEND ON THE MODEL TRUCK YOU HAVE. SEE FIGURE 11 TO DETERMINE WHICH HOLES TO USE FOR INSERTING THE CARRIAGE BOLTS.

1. Insert a long 3/8" bolt (N) and flat washer (J) into one of the two bottom holes of the locating bracket (V) (fig. 11).

### NOTE

*Use the hole that is closest to the leaf spring.*

- 2a. If you are installing this kit on a single rear wheel (SRW) vehicle, use position 2 to insert the long carriage bolt through the top of the locating bracket and lower bracket (fig. 11a).
- 2b. If you are installing this kit on a dual rear wheel (DRW) vehicle, use position 1 to insert the long carriage bolt through the top of the locating bracket and lower bracket (fig. 11a).
3. Attach the locating bracket (V) to the lower bracket with a 3/8" carriage bolt (Y), flat washer (J) and nyloc nut (O) using the remaining slot in the top of the locating bracket. Leave loose at this time.
4. With the exception of the 2WD dual rear model (see 2WD DRW Models), push the front and back locating brackets against the u-bolts and tighten the short carriage bolts at this time.
5. Using the 3/8" long bolts (N) and flat washers (J) previously installed on the locating brackets, insert them into the spring clamp bar (F) on the opposite side of the leaf spring assembly (fig. 11). Cap with 3/8" flat washers (J) and nyloc nuts (O). Leave loose at this time.

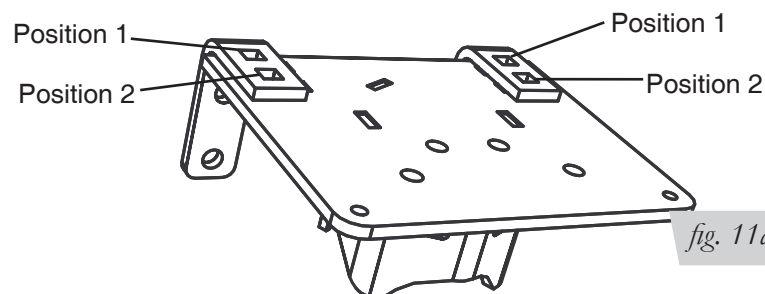

6. Set the axle clamp bar (D) onto the long 3/8" carriage bolts (M) (fig. 11) and cap with 3/8" flat washers (J) and nyloc nuts (O).
7. Carefully draw the side hardware and axle hardware evenly. Torque the spring clamp bar bolts to 10 ft/lbs and the axle clamp bar bolts to 16 ft/lbs. Repeat for opposite side. Trim carriage bolts below nyloc nuts if necessary.

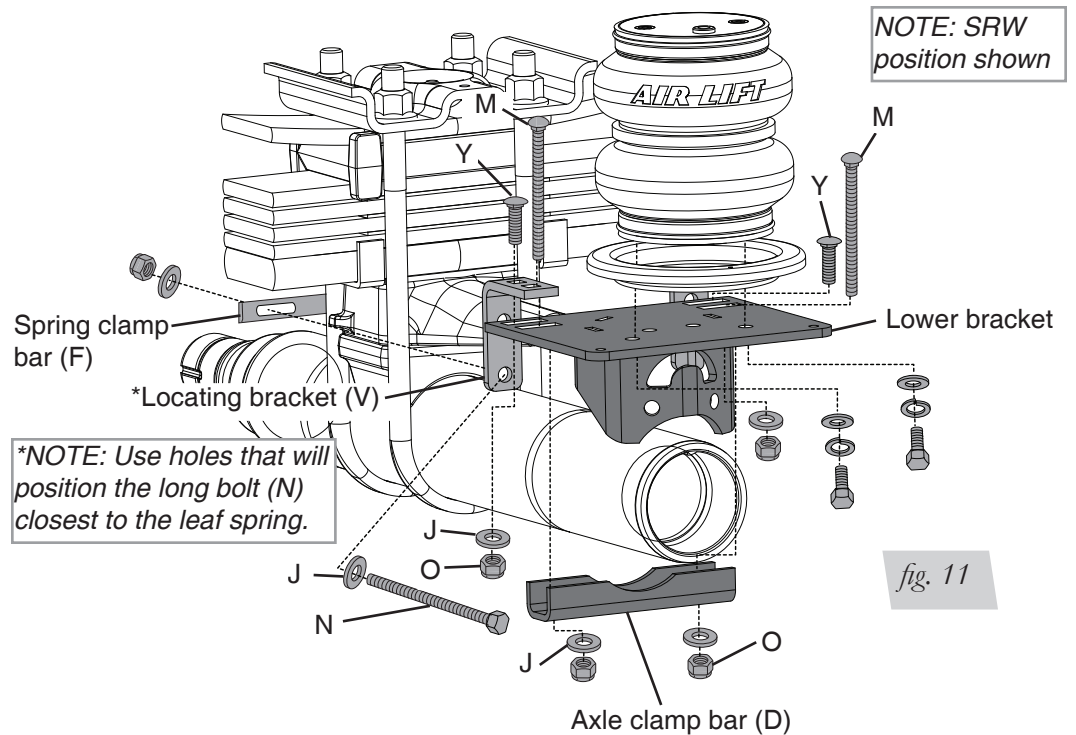

## 2WD DRW MODELS

1. Remove the rear brake line bolts holding the brake lines to the spring perch behind the axle and discard (fig. 12).
2. Attach the three hole locating bracket (W) onto the spring perch by using the new bolt supplied (Z) (fig. 12). Insert the bolt through the stock brake line bracket previously removed, then through the locating bracket and into the spring perch using the existing hole the stock bolt was previously removed from. Leave loose at this time.

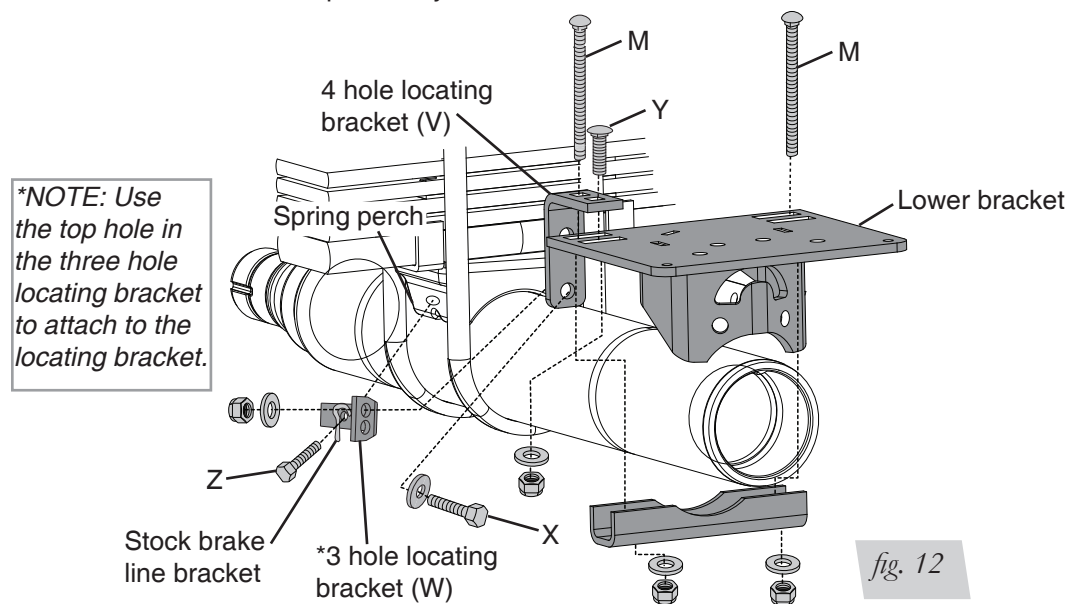

**NOTE**

*We recommend a medium Loctite (blue) on the bolt threads.*

3. Attach the four hole locating bracket to the rear set of slots on the lower bracket. Use one 3/8" -16 x 1.25 carriage bolt (Y) through the inboard slot and cap with a flat washer (J) and nyloc nut (O). Then insert the long 3/8" -16 x 10 carriage bolt (M) through the outside slot (fig. 12). Leave loose at this time.
4. Rotate the lower bracket back on the axle and attach the four hole locating bracket to the three hole locating bracket so the lower bracket is parallel to the upper bracket. Use the top hole of the three hole bracket to attach the two together with 3/8" bolts (X), flat washers (J), and nyloc nuts (O) (fig. 3 and 12). Tighten all hardware securely.

**NOTE**

*For 2WD and 4WD DRW vehicles, in order to install the sway bar and sway bar retaining straps back onto the axle, it will be necessary to slot the retaining straps (fig. 13). Reattach the sway bar once this is done.*

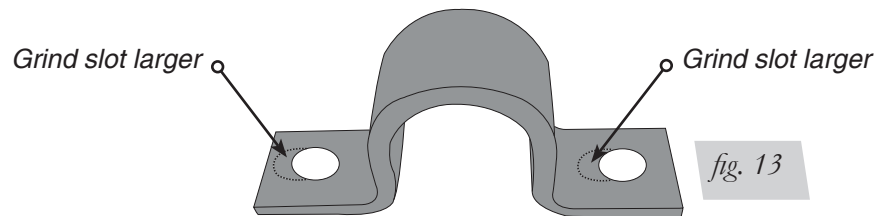
**FINAL STEPS**

1. The emergency brake cable will have to be re-located away from the bellows.

**CAUTION**

**FAILURE TO DO SO MAY CAUSE FAILURE TO THE BELLOWS AND VOID THE WARRANTY.**

2. Secure the emergency brake cable to the bottom bracket with supplied wire tie using the hole in the corner of the lower bracket (fig. 14).

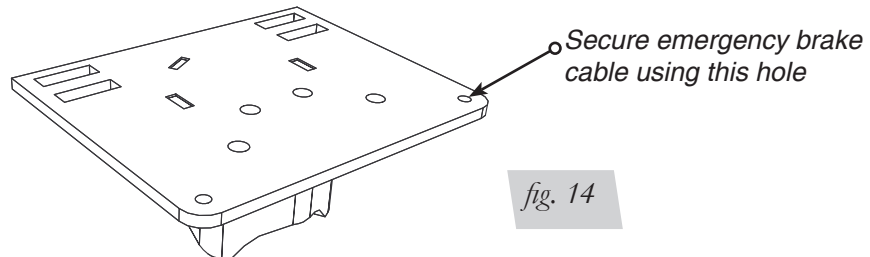

3. Install the fitting into the top of the bellows finger tight. Tighten swivel fitting one and a half turns.

**INSTALLING THE AIR LINES**

1. Choose a convenient location for mounting the inflation valves. Popular locations for the inflation valve are:
  - a. The wheel well flanges
  - b. The license plate recess in bumper
  - c. Under the gas cap access door
  - d. Through the license plate

**NOTE**

*Whatever the chosen location, make sure there is enough clearance around the inflation valves for an air chuck.*

2. Drill two 5/16" holes to install the inflation valves.
3. Cut the air line assembly in two equal lengths.

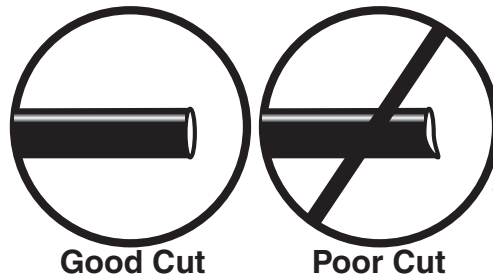

fig. 15

**CAUTION**

WHEN CUTTING OR TRIMMING THE AIR LINE, USE A HOSE CUTTER, A RAZOR BLADE, OR A SHARP KNIFE. A CLEAN, SQUARE CUT WILL ENSURE AGAINST LEAKS. DO NOT USE WIRE CUTTERS OR SCISSORS TO CUT THE AIR LINE. THESE TOOLS MAY FLATTEN OR CRIMP THE AIR LINE CAUSING IT TO LEAK AROUND THE O-RING SEAL INSIDE THE ELBOW FITTING (FIG. 15).

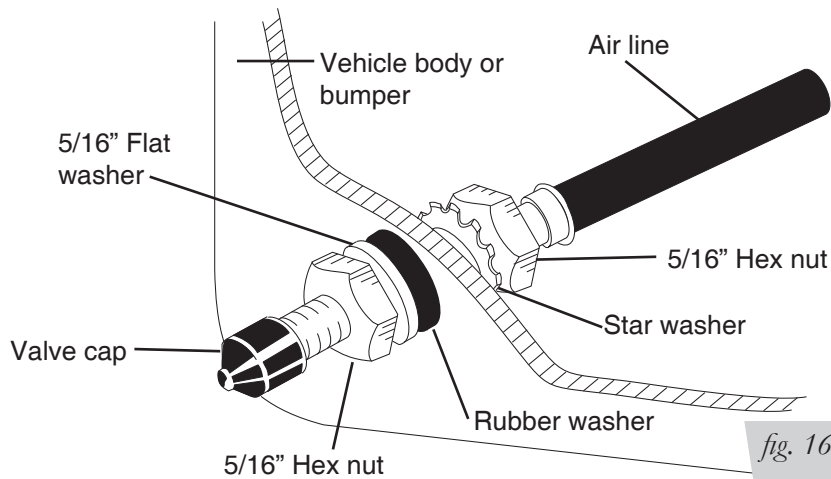

fig. 16

4. Place a 5/16" nut and star washer on the air valve. Leave enough of the inflation valve in front of the nut to extend through the hole and have room for the rubber washer, flat washer, and 5/16" nut and cap. There should be enough valve exposed after installation—approximately 1/2"—to easily apply a pressure gauge or an air chuck (fig. 16).
5. Push the inflation valve through the hole and use the rubber washer, flat washer, and another 5/16" nut to secure it in place. Tighten the nuts to secure the assembly.
6. Route the air line along the frame to the air fitting on the air spring (fig. 17). Keep AT LEAST 6" of clearance between the air line and heat sources, such as the exhaust pipes, muffler, or catalytic converter. Avoid sharp bends and edges. Use the plastic tie straps to secure the air line to fixed, non-moving points along the chassis. Be sure that the tie straps are tight, but do not pinch the air line. Leave at least 2" of slack to allow for any movement that might pull on the air line (fig. 17).

Secure Air Lines with Provided Tie Straps

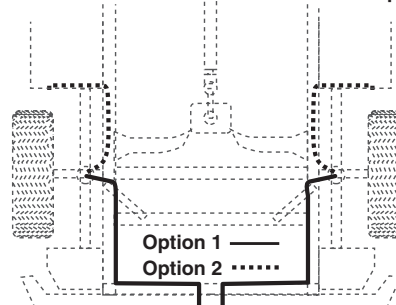

fig. 17

7. Cut off the air line, leaving approximately 12" of extra air line. A clean square cut will ensure against leaks. Insert the air line into the air fitting. This is a push-to-connect fitting. Simply push the air line into the 90° swivel fitting until it bottoms out (9/16" of air line should be in the fitting).
8. Install the minimum/maximum air pressure decal in a highly visible location. We suggest placing the decal on the driver-side window, just above the door handle.

## INSTALLING THE HEAT SHIELD

1. Bend tabs to provide a ½" dead air space between exhaust pipe and heat shield (fig. 18).
2. Attach the heat shield to the exhaust pipe using the clamps. Bend the heat shield for maximum clearance to the air spring (fig. 18).

### NOTE

*If your model comes with an exhaust resonator near the installation location, you will need two 5.5" hose clamps to install the heat shield (fig. 18a).*

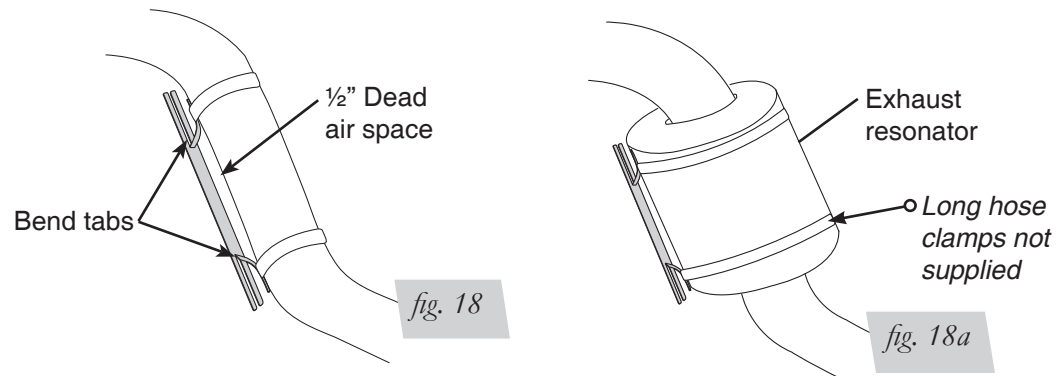

## CHECKING FOR LEAKS

1. Inflate the air spring to 30 p.s.i.
2. Spray all connections and the inflation valves with a solution of 1/5 liquid dish soap and 4/5 water. Spot leaks easily by looking for bubbles in the soapy water.
3. After the test, deflate the springs to the minimum pressure required to restore the system to normal ride height. Do not deflate to lower than 5 p.s.i.
4. Check the air pressure again after 24 hours. A 2 - 4 p.s.i. loss after initial installation is normal. Retest for leaks if the loss is more than 5 lbs.

## FIXING LEAKS

1. If there is a problem with the swivel fitting:
  - a. Check the air line connection by deflating the spring and removing the line by pulling the collar against the fitting and pulling firmly on the air line. Trim 1" off the end of the air line. Be sure the cut is clean and square (see fig. #). Reinsert the air line into the push-to-connect fitting.
  - b. Check the threaded connection by tightening the swivel fitting another ½ turn. If it still leaks, deflate the air spring, remove the fitting, and re-coat the threads with thread sealant. Reinstall by hand tightening as much as possible and then use a wrench for an additional two turns.
2. If there is a problem with the inflation valve:
  - a. Check the valve core by tightening it with a valve core tool.
  - b. Check the air line by removing the air line from the barbed type fitting. Cut the air line off a few inches in front of the fitting and use a pair of pliers or vice grips to pull/twist the air line off of the fitting.



**CAUTION**

DO NOT CUT OFF THE AIR LINE COMPLETELY AS THIS WILL USUALLY NICK THE BARB AND RENDER THE FITTING USELESS.

3. If the preceding steps have not resolved the problem, call Air Lift customer service at (800) 248-0892.

## Before Operating

### INSTALLATION CHECKLIST (To be completed by installer)

- Clearance test — Inflate the air springs to 60 p.s.i. and ensure there is at least ½” clearance around each bellow, away from anything that might rub against them. Be sure to check the tire, brake drum, frame, shock absorbers and brake cables.
- Leak test before road test — Inflate the air springs to 60 p.s.i., check all connections for leaks with a soapy water solution. See page 8 for tips on how to spot leaks. All leaks must be eliminated before the vehicle is road tested.
- Heat test — Be sure there is sufficient clearance from any heat sources — at least 6” for air springs and air lines. If a heat shield was included in the kit, install it. If there is no heat shield, but one is required, call (800) 248-0892.
- Fastener test — Recheck all bolts for proper torque. Axle straps carriage bolt lock nuts should be torqued to 16 ft/lbs. Re-torque after 100 miles.
- Road test — The vehicle should be road tested after the preceding tests. Inflate the air springs to 25 p.s.i. (50 p.s.i. if the vehicle is loaded). Drive the vehicle 10 miles and recheck for clearance, loose fasteners and air leaks.
- Operating instructions — If professionally installed, the installer should review the operating instructions on page 10 with the owner. Be sure to provide the owner with all of the paperwork which came with the kit.

**Technician's Signature** \_\_\_\_\_

**Date** \_\_\_\_\_

### POST-INSTALLATION CHECKLIST (To be completed by owner)

- Overnight leakdown test — Recheck air pressure after vehicle has been used for 24 hours. If pressure has dropped more than 5 p.s.i., check for leaks and fix accordingly following the instructions on page 8 or return to the installer for service.
- Air pressure requirements — The air pressure requirements are detailed on page 16. Regardless of the load, the air pressure should always be adjusted so that normal ride height is maintained at all times.
- 30 day or 500 mile test — The air spring system must be rechecked after 30 days or 500 miles, whichever comes first. If any part shows signs of rubbing or abrasion, the source should be identified and moved, if possible. If it is not possible to relocate the cause of the abrasion, the air spring may need to be remounted. If professionally installed, the installer should be consulted. Check all fasteners for tightness.

# Maintenance and Operations

Minimum Air Pressure	Maximum Air Pressure
5 p.s.i.	100 p.s.i.
FAILURE TO MAINTAIN CORRECT MINIMUM PRESSURE (OR PRESSURE PROPORTIONAL TO LOAD), BOTTOMING OUT, OVER-EXTENSION OR RUBBING AGAINST ANOTHER COMPONENT WILL VOID THE WARRANTY.	

## MAINTENANCE GUIDELINES

### NOTE

*By following the steps below, vehicle owners will obtain the longest life and best results from their air springs.*

1. Check the air pressure weekly.
2. Always maintain normal ride height. Never inflate beyond 100 p.s.i.
3. If you develop an air leak in the system, use a soapy water solution (1/5 liquid dish soap and 4/5 water) to check all air line connections and the inflation valve core before deflating and removing the air spring.



### CAUTION

FOR YOUR SAFETY AND TO PREVENT POSSIBLE DAMAGE TO YOUR VEHICLE, DO NOT EXCEED MAXIMUM GROSS VEHICLE WEIGHT RATING (GVWR), AS INDICATED BY THE VEHICLE MANUFACTURER. ALTHOUGH YOUR AIR SPRINGS ARE RATED AT A MAXIMUM INFLATION PRESSURE OF 100 P.S.I., THE AIR PRESSURE ACTUALLY NEEDED IS DEPENDANT ON YOUR LOAD AND GVWR.

4. Loaded vehicles require at least 25 p.s.i. or more. A "loaded vehicle" refers to a vehicle with a heavy bed load, a trailer, or both. As discussed above, never exceed GVWR, regardless of air spring, air pressure, or other load assist. The springs in this kit will support approximately 40 lbs. of load (combined on both springs) for each 1 p.s.i. of pressure. The required air pressure will vary depending on the state of the original suspension. Operating the vehicle below the minimum air spring pressure will void the Air Lift warranty.
5. When increasing load, always adjust the air pressure to maintain the normal ride height. Increase or decrease pressure from the system as necessary to attain normal ride height for optimal ride and handling. Remember that loads carried behind the axle (including tongue loads) require more leveling force (pressure) than those carried directly over the axle.
6. Always add air to springs in small quantities, checking the pressure frequently.
7. Should it become necessary to raise the vehicle by the frame, make sure the system is at minimum pressure (5 p.s.i.) to reduce the tension on the suspension/brake components. Use of on board leveling systems do not require deflation or disconnection.
8. Periodically check the air spring system fasteners for tightness. Also, check the air springs for any signs of rubbing. Realign if necessary.
9. On occasion, give the air springs a hard spray with a garden hose in order to remove mud, sand, gravel or other abrasive debris.

# Product Use

## FREQUENTLY ASKED QUESTIONS

### Q. Will installing air springs increase the weight ratings of a vehicle?

No. Adding air springs will not change the weight ratings (GAWR, GCWR and/or GVWR) of a vehicle. Exceeding the GVWR is dangerous and voids the Air Lift warranty.

### Q. Is it necessary to keep air in the air springs at all times and how much pressure will they need?

The minimum air pressure should be maintained at all times. The minimum air pressure keeps the air spring in shape, ensuring that it will move throughout its travel without rubbing or wearing on itself.

### Q. Is it necessary to add a compressor system to the air springs?

No. Air pressure can be adjusted with any type of compressor as long as it can produce sufficient pressure to service the springs. Even a bicycle tire pump can be used, but it's a lot of work.

### Q. How long should air springs last?

If the air springs are properly installed and maintained they can last indefinitely.

### Q. Will raising the vehicle on a hoist for service work damage the air springs?

No. The vehicle can be lifted on a hoist for short-term service work such as tire rotation or oil changes. However, if the vehicle will be on the hoist for a prolonged period of time, support the axle with jack stands in order to take the tension off of the air springs.

## TUNING THE AIR PRESSURE

Pressure determination comes down to three things — level vehicle, ride comfort, and stability.

### 1. Level vehicle

If the vehicle's headlights are shining into the trees or the vehicle is leaning to one side, then it is not level (fig. 19). Raise the air pressure to correct either of these problems and level the vehicle.

### 2. Ride comfort

If the vehicle has a rough and harsh ride it may be due to either too much pressure or not enough (fig. 20). Try different pressures to determine the best ride comfort.

### 3. Stability

Stability translates into safety and should be the priority, meaning the driver may need to sacrifice a perfectly level and comfortable ride. Stability issues include roll control, bounce, dive during braking and sponginess (fig. 21). Tuning out these problems usually requires an increase in pressure.



Bad headlight aim

fig. 19



Rough ride

fig. 20



Sway and body roll

fig. 21

## GUIDELINES FOR ADDING AIR

1. Start with the vehicle level or slightly above.
2. When in doubt, always add air.
3. For motorhomes, start with 50-100 p.s.i. in the rear because it can be safely assumed that it is heavily loaded.
4. If the front of the vehicle dives while braking, increase the pressure in the front air bags, if equipped.
5. If it is ever suspected that the air bags have bottomed out, increase the pressure (fig. 22).
6. Adjust the pressure up and down to find the best ride.
7. If the vehicle rocks and rolls, adjust the air pressure to reduce movement.
8. It may be necessary to maintain different pressures on each side of the vehicle. Loads such as water, fuel, and appliances will cause the vehicle to be heavier on one side (fig. 23). As much as a 50 p.s.i. difference is not uncommon.



Bottoming out

*fig. 22*

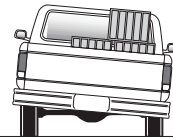

Unlevel

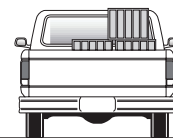

Level

*fig. 23*



# Warranty and Returns Policy

Air Lift Company warrants its products, for the time periods listed below, to the original retail purchaser against manufacturing defects when used on catalog-listed applications on cars, vans, light trucks and motorhomes under normal operating conditions for as long as Air Lift manufactures the product. The warranty does not apply to products that have been improperly applied, improperly installed, used in racing or off-road applications, used for commercial purposes, or which have not been maintained in accordance with installation instructions furnished with all products. The consumer will be responsible for removing (labor charges) the defective product from the vehicle and returning it, transportation costs prepaid, to the dealer from which it was purchased or to Air Lift Company for verification.

Air Lift will repair or replace, at its option, defective products or components. A minimum \$10.00 shipping and handling charge will apply to all warranty claims. Before returning any defective product, you must call Air Lift at (800) 248-0892 in the U.S. and Canada (elsewhere, (517) 322-2144) for a Returned Materials Authorization (RMA) number. Returns to Air Lift can be sent to: Air Lift Company • 2727 Snow Road • Lansing, MI • 48917.

Product failures resulting from abnormal use or misuse are excluded from this warranty. The loss of use of the product, loss of time, inconvenience, commercial loss or consequential damages is not covered. The consumer is responsible for installation/reinstallation (labor charges) of the product. Air Lift Company reserves the right to change the design of any product without assuming any obligation to modify any product previously manufactured.

This warranty gives you specific legal rights and you may also have other rights that vary from state-to-state. Some states do not allow limitations on how long an implied warranty lasts or allow the exclusion or limitation of incidental or consequential damages. The above limitation or exclusion may not apply to you. There are no warranties, expressed or implied including any implied warranties of merchantability and fitness, which extend beyond this warranty period. There are no warranties that extend beyond the description on the face hereof. Seller disclaims the implied warranty of merchantability. (Dated proof of purchase required.)

<b>Air Lift 1000</b> .....	<b>Lifetime Limited</b>	<b>Load Controller (I)</b> .....	<b>2 Year Limited</b>
<b>RideControl</b> .....	<b>Lifetime Limited</b>	<b>Load Controller (II)</b> .....	<b>2 Year Limited</b>
<b>SlamAir</b> .....	<b>Lifetime Limited</b>	<b>SmartAir</b> .....	<b>2 Year Limited</b>
<b>LoadLifter 5000*</b> .....	<b>Lifetime Limited</b>	<b>Wireless AIR</b> .....	<b>2 Year Limited</b>
<b>LifeStyle**</b> .....	<b>1 Year Limited</b>	<b>Other Accessories</b> .....	<b>2 Year Limited</b>

*\*formerly SuperDuty  
\*\*formerly EasyStreet*

## Replacement Information

If you need replacement parts, contact the local dealer or call Air Lift customer service at (800) 248-0892. Most parts are immediately available and can be shipped the same day.

**Contact Air Lift Company customer service at (800) 248-0892 first if:**

- Parts are missing from the kit.
- Need technical assistance on installation or operation.
- Broken or defective parts in the kit.
- Wrong parts in the kit.
- Have a warranty claim or question.

**Contact the retailer where the kit was purchased:**

- If it is necessary to return or exchange the kit for any reason.
- If there is a problem with shipping if shipped from the retailer.
- If there is a problem with the price.

## Contact Information

If you have any questions, comments or need technical assistance contact our customer service department by calling (800) 248-0892, Monday through Friday, 8 a.m. to 7 p.m. Eastern Time. For calls from outside the USA or Canada, our local number is (517) 322-2144.

For inquiries by mail, our address is PO Box 80167, Lansing, MI 48908-0167. Our shipping address for returns is 2727 Snow Road, Lansing, MI 48917.

You may also contact us anytime by e-mail at [sales@airliftcompany.com](mailto:sales@airliftcompany.com) or on the Web at [www.airliftcompany.com](http://www.airliftcompany.com).



## Need Help?

Contact our customer service department by calling (800) 248-0892, Monday through Friday, 8 a.m. to 7 p.m. Eastern Time. For calls from outside the USA or Canada, our local number is (517) 322-2144.

**Register your warranty online at  
[www.airliftcompany.com/warrantyreg.htm](http://www.airliftcompany.com/warrantyreg.htm)**



*Thank you for purchasing Air Lift products — the professional installer's choice!*

Air Lift Company • 2727 Snow Road • Lansing, MI 48917 or PO Box 80167 • Lansing, MI 48908-0167  
Toll Free (800) 248-0892 • Local (517) 322-2144 • Fax (517) 322-0240 • [www.airliftcompany.com](http://www.airliftcompany.com)

Printed in  
the USA