

AutoPilot™

DIGITAL CONTROL SYSTEM
by AIR LIFT®

Kits 27630 and 27631



INSTALLATION GUIDE

WARNING:
In case of battery failure -
unplug the controller
before jump starting vehicle!

For maximum effectiveness and safety,
please read these instructions completely
before proceeding with installation.

*Failure to read these instructions can result in an
incorrect installation.*

TABLE OF CONTENTS

Introduction	2
Important Safety Notice	2
Notation Explanation	2
Installing the AutoPilot Digital Controller	3
ECU Diagram	3
How to “Tune” Your ECU	3
How to Set Your “Ride Height”	4
Recommended Compressor Locations	5
Installing the Compressor and Manifold	5
Installing the Air Tank and Components	6
Installing the Electrical Components	7
Attaching the Air Lines	8
Mounting the Display Panel	9
Kit Installation Diagram	10-11
Attaching the ECU and Display Panel	12
Troubleshooting Guide	12
Checking the System	12
To Add a Second Compressor	12
Troubleshooting Guide	13
Operational Instructions	13
Three Basic Operation Modes	13
Settings	14
User Interface	14
Warranty and Returns Policy	16
Replacement Information	17
Contact Information	17

Introduction

The purpose of this publication is to assist with the installation, maintenance and troubleshooting of the AutoPilot Digital Controller.

It is important to read and understand the entire installation guide before beginning installation or performing any maintenance, service or repair. The information here includes a hardware list, tool list, step-by-step installation information, maintenance guidelines and operating tips.

Air Lift Company reserves the right to make changes and improvements to its products and publications at any time. For the latest version of this manual, contact Air Lift Company at (800) 248-0892 or visit our website at www.airliftcompany.com.

IMPORTANT SAFETY NOTICE

The installation of this kit does not alter the Gross Vehicle Weight Rating (GVWR) or payload of the vehicle. Check your vehicle's owner's manual and do not exceed the maximum load listed for your vehicle.

Gross Vehicle Weight Rating: The maximum allowable weight of the fully loaded vehicle (including passengers and cargo). This number — along with other weight limits, as well as tire, rim size and inflation pressure data — is shown on the vehicle's Safety Compliance Certification Label.

Payload: The combined, maximum allowable weight of cargo and passengers that the truck is designed to carry. Payload is GVWR minus the Base Curb Weight.

NOTATION EXPLANATION

Hazard notations appear in various locations in this publication. Information which is highlighted by one of these notations must be observed to help minimize risk of personal injury or possible improper installation which may render the vehicle unsafe. Notes are used to help emphasize areas of procedural importance and provide helpful suggestions. The following definitions explain the use of these notations as they appear throughout this guide.



DANGER

INDICATES IMMEDIATE HAZARDS WHICH WILL RESULT IN SEVERE PERSONAL INJURY OR DEATH.



WARNING

INDICATES HAZARDS OR UNSAFE PRACTICES WHICH COULD RESULT IN SEVERE PERSONAL INJURY OR DEATH.



CAUTION

INDICATES HAZARDS OR UNSAFE PRACTICES WHICH COULD RESULT IN DAMAGE TO THE MACHINE OR MINOR PERSONAL INJURY.

NOTE

Indicates a procedure, practice or hint which is important to highlight.

Installing the AutoPilot Digital Controller

ECU DIAGRAM

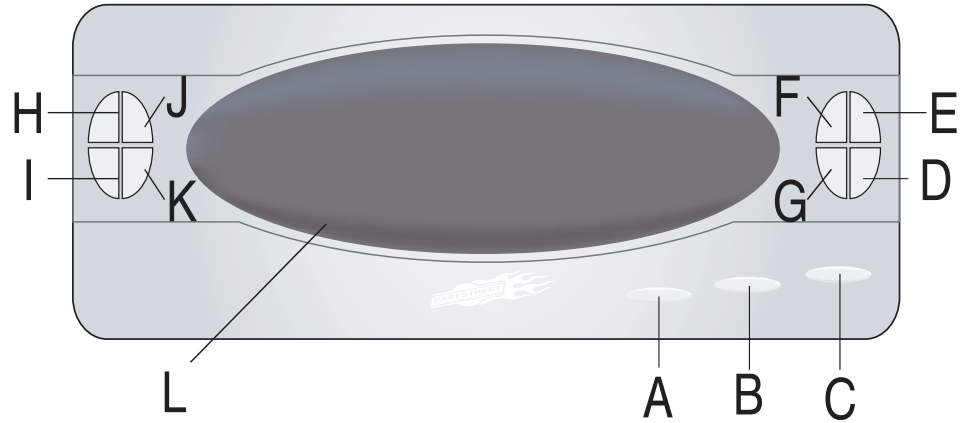


fig. 1

A. All Lowered	G. Left Rear Deflate
B. Ride Height and Access Menu Features	H. Left Front Inflate
C. All Raised	I. Left Front Deflate
D. Right Rear Deflate	J. Right Front Inflate
E. Right Rear Inflate	K. Right Front Deflate
F. Left Rear Inflate	L. Display Screen

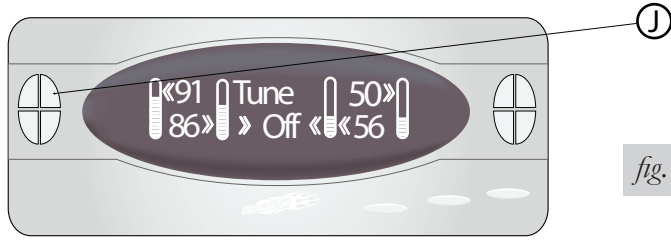
HOW TO “TUNE” YOUR ECU

1. Press and hold the “B” button for three seconds until the menu is accessed (fig. 2).

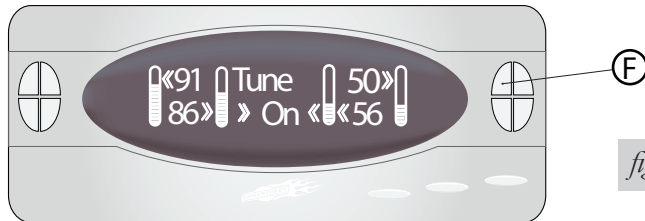


fig. 2

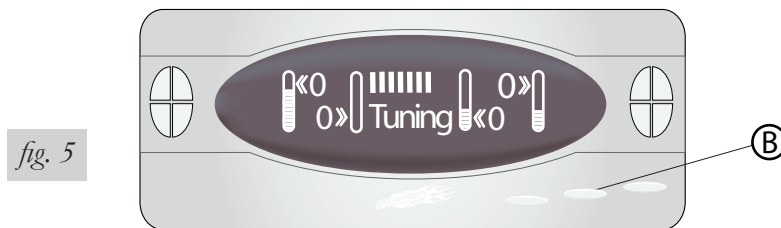
2. Press the “J” button to scroll through the menu options until you see “Tune” (fig. 3).


fig. 3

3. Press button “F” to turn the tune function on (fig. 4).

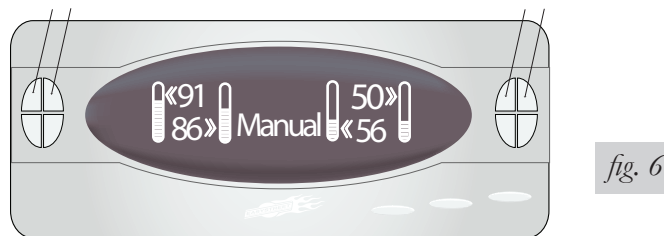

fig. 4

4. Make sure your tank is full. Check to ensure all is clear for the system to be cycled. Press button “B”. Your system should now be tuning (fig. 5).

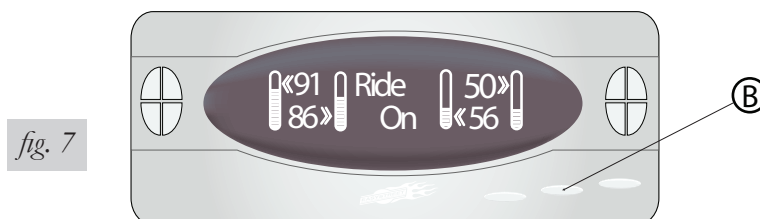

fig. 5

HOW TO SET YOUR “RIDE HEIGHT”

1. Make sure you have your system tuned. “See Above”
2. In Manual Mode lift your vehicle to your desired height and pressure (fig. 6).


fig. 6

3. Hold “B” for two seconds until “Ride” appears on the screen. These pressures are now set as your ride height (fig. 7).


fig. 7

RECOMMENDED COMPRESSOR LOCATIONS

Important

LOCATE COMPRESSOR IN DRY, PROTECTED AREA ON VEHICLE.
 DIRECT SPLASH OR EXCESSIVE MOISTURE CAN DAMAGE
 THE COMPRESSOR AND CAUSE SYSTEM FAILURE.

Disclaimer: If you choose to mount the compressor outside the vehicle please keep in mind the compressor body must be shielded from direct splash and the intake should be snorkeled inside the vehicle. If the compressor does not include a remote mount air filter or if mounting the compressor outside the vehicle, make sure to orient the compressor intake filter so that all moisture can easily drain.

Please also remember...

- To avoid high heat environments
- To avoid mounting the compressor under the hood.
- To check to be sure the compressor harness #2 will reach the compressor and connect to harness #1.
- The compressor can be mounted in any position — vertical, upside down, sideways, etc. (please refer to the instruction manual).

INSTALLING THE COMPRESSOR AND MANIFOLD

1. Attach the filter to the port on the end of the compressor (Fig. 8).
2. Attach air fittings to the remaining three ports on each manifold (Fig. 8).
3. Select a rigid mounting location on your vehicle’s frame or crossmember that shields the compressor from the elements and heat sources (Fig. 8).
4. Attach the compressor to the frame rail or crossmember using Fig. 8 as a guide.

NOTE

The compressor and manifolds must be mounted within reach of the wires when the wiring harness is plugged in.

5. Attach the brackets to the manifold using the provided screws.
6. Attach the brackets to the chosen mounting location using the provided self-tapping screws.

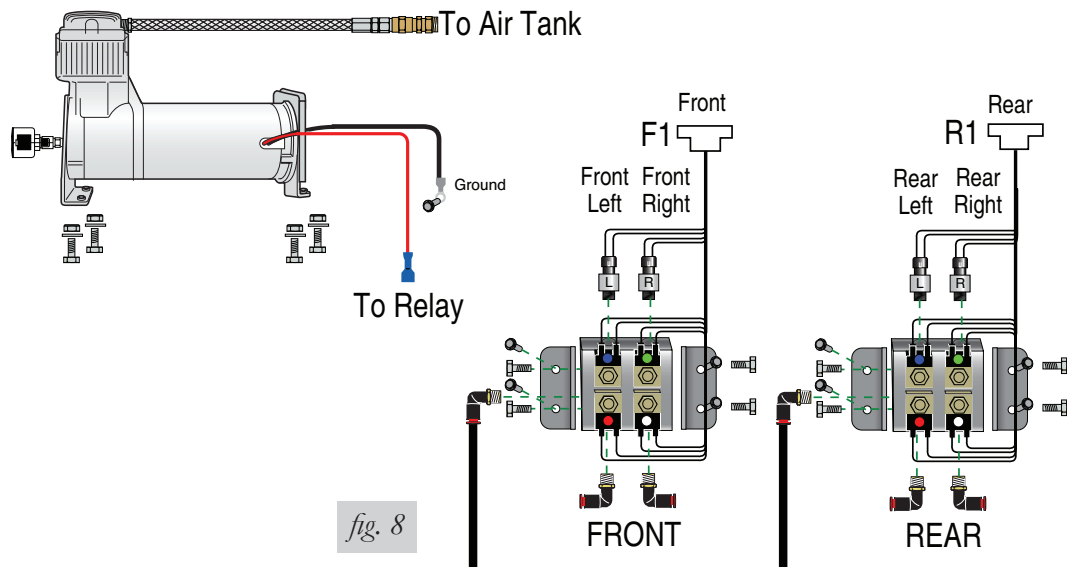
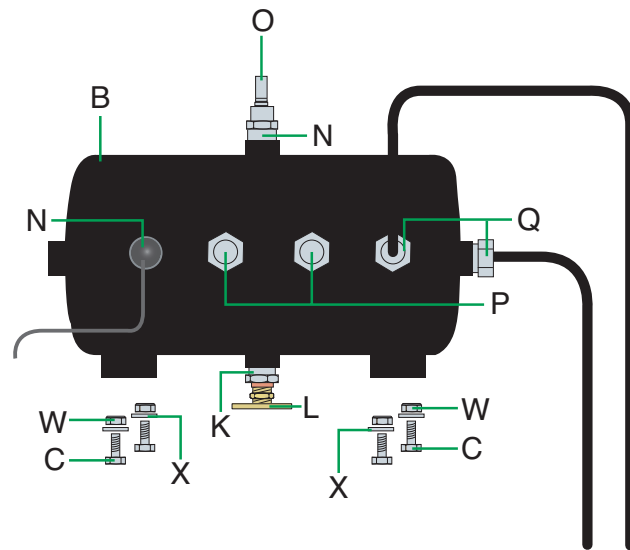


fig. 8

	1	2	3
<i>Compressor</i>	Centerpunch and drill four 1/4" diameter holes using the compressor feet as a template.	Attach using four supplied screws.	Fasten using four supplied washers and nuts.
<i>Manifold</i>	Centerpunch and drill two 3/16" diameter holes for each using the manifold as a template.	Attach using the supplied lock washers and bolts.	
<i>CAUTION</i>	Mount the compressor and manifolds at least 6" from any heat sources. DO NOT mount the compressor or the manifolds in the engine		

INSTALLING THE AIR TANK AND COMPONENTS



IMPORTANT: Depending on the orientation of the tank when it is mounted, the fittings may go into different ports on the tank. The drain valve must always be put into the port facing downwards (Fig. 9).

IMPORTANT: Apply the provided thread sealant to all of the air tank fittings that have not been pre-coated with sealant.

IMPORTANT: When choosing a mounting location for the air tank, be sure that there is ample room for the air lines and that they will be clear of any heat sources.

1. Attach a 1/2" x 1/2" tube elbow to the the other end.
2. Attach a 1/2" x 1/8" bushing to the port of the air tank that will be facing upwards and attach an inflation valve to the port.
3. Attach a 1/2" x 1/4" bushing to the port on the air tank that will be facing downwards and attach the drain valve to this bushing.
4. Attach two 1/2" hex head pipe plugs to two of the four ports on the front of the tank.
5. Attach a 1/2" x 1/8" bushing to one of the remaining ports on the front of the air tank. Attach the transducer to this bushing.
6. Attach a 1/2" x 1/2" tube elbow to the remaining port.
7. Mount the air tank in the chosen location using the provided bolts, flat washers and nyloc nuts.

INSTALLING THE ELECTRICAL COMPONENTS

1. Run the harness from the dash to the manifold/compressor location.

NOTE

Place a grommet or silicone sealant around any holes that the harness passes through to protect it from abrasive surfaces.

2. Connect the transducer wires to the corresponding transducers on the manifolds (Fig. 10).

IMPORTANT: Ensure that the cable seal is in place before connecting the transducer wires.

CAUTION

FAILURE TO MAKE SURE THE CABLE SEAL IS IN PLACE WILL PROMOTE CORROSION OF THE CONNECTORS AND WILL CAUSE PREMATURE FAILURE OF THE DIGITAL CONTROL SYSTEM.

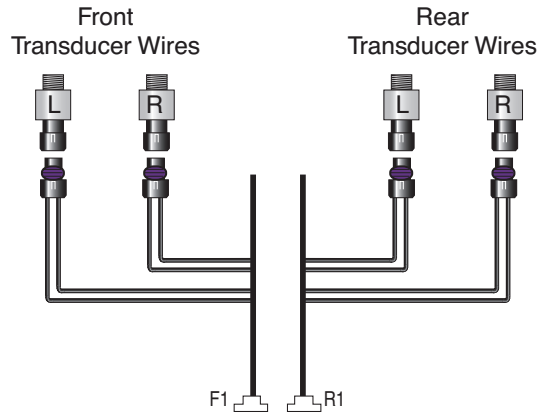


fig. 10

3. Connect the transducer with the three black wires to the open port in the front of the air tank as shown in Fig. 11.

IMPORTANT:
Power to the ECU must connect to an accessory source. The accessory source powers the radio, sunroof and other items powered through the accessory circuit and NOT the ignition circuit. Failure to connect to an accessory source WILL CAUSE THE DISPLAY TO FAIL and will void the warranty.

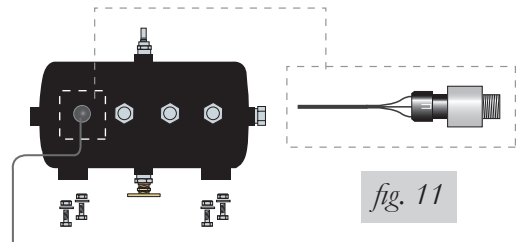


fig. 11

4. Attach the corresponding connectors from the ECU to the manifold (Fig. 12).

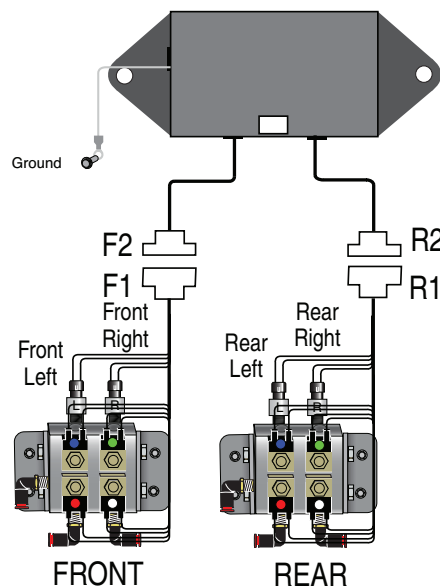
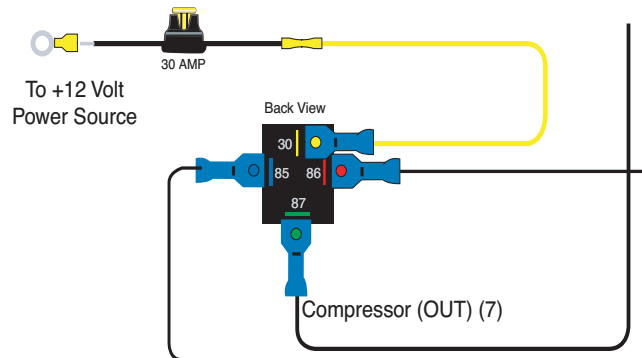


fig. 12

- Using a butt connector, attach the 12 gauge wire from terminal 30 on the back of the relay to one end of the 30 amp fuse holder (Fig. 13).

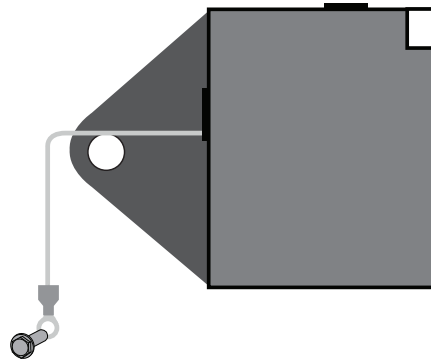


- If choosing to use the ring terminal, attach it to the other end of the fuse wire (Fig. 13).
- Choose an appropriate 12+ volt source on the vehicle.

NOTE

A direct connection to the battery is suggested.

- Attach a ground terminal to the small white wire coming out of the back of the ECU/ Display Connector (Fig. 14).



- Using a butt connector, attach the 5 amp fuse to the small red wire on the ECU and then attach the wire and fuse to an accessory terminal in the fuse panel.

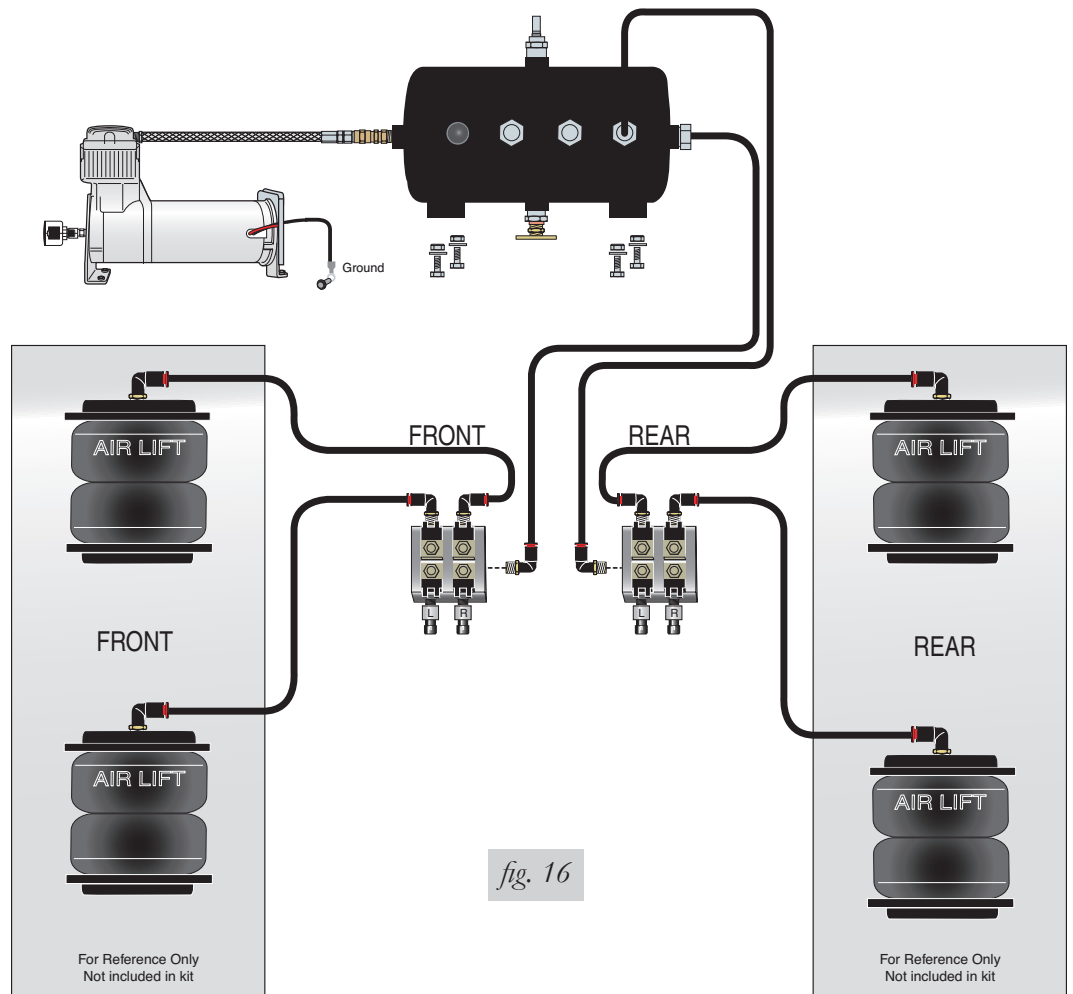
ATTACHING THE AIR LINES

- Insert three 3/8" x 1/2" air fittings into the ports of the manifolds. There are two ports on one side and one port on the other (Figure 9).
- Using a standard tube cutter, a razor blade, or a very sharp knife, squarely cut two pieces of 1/2" air line to go between each of the front air springs and the two ports of the manifold (Fig. 16).
- Repeat step 2 for the rear air bags with the rear manifold.
- Cut a length of air line to go between the front manifold and an end port of the air tank.
- Cut another length of air line to go between the rear manifold and one of the front ports of the air tank.

NOTE

A definite click will be heard/felt when the air line is properly seated. The air line should go in approximately 9/16".

- Attach the fitting at the end of the braided leader hose on the compressor to the end port of the air tank (Fig. 16).



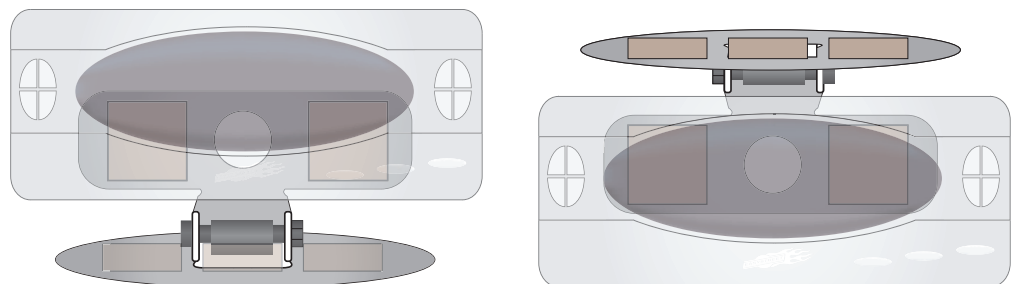
MOUNTING THE DISPLAY PANEL

1. Determine the mounting location of the display panel.

NOTE

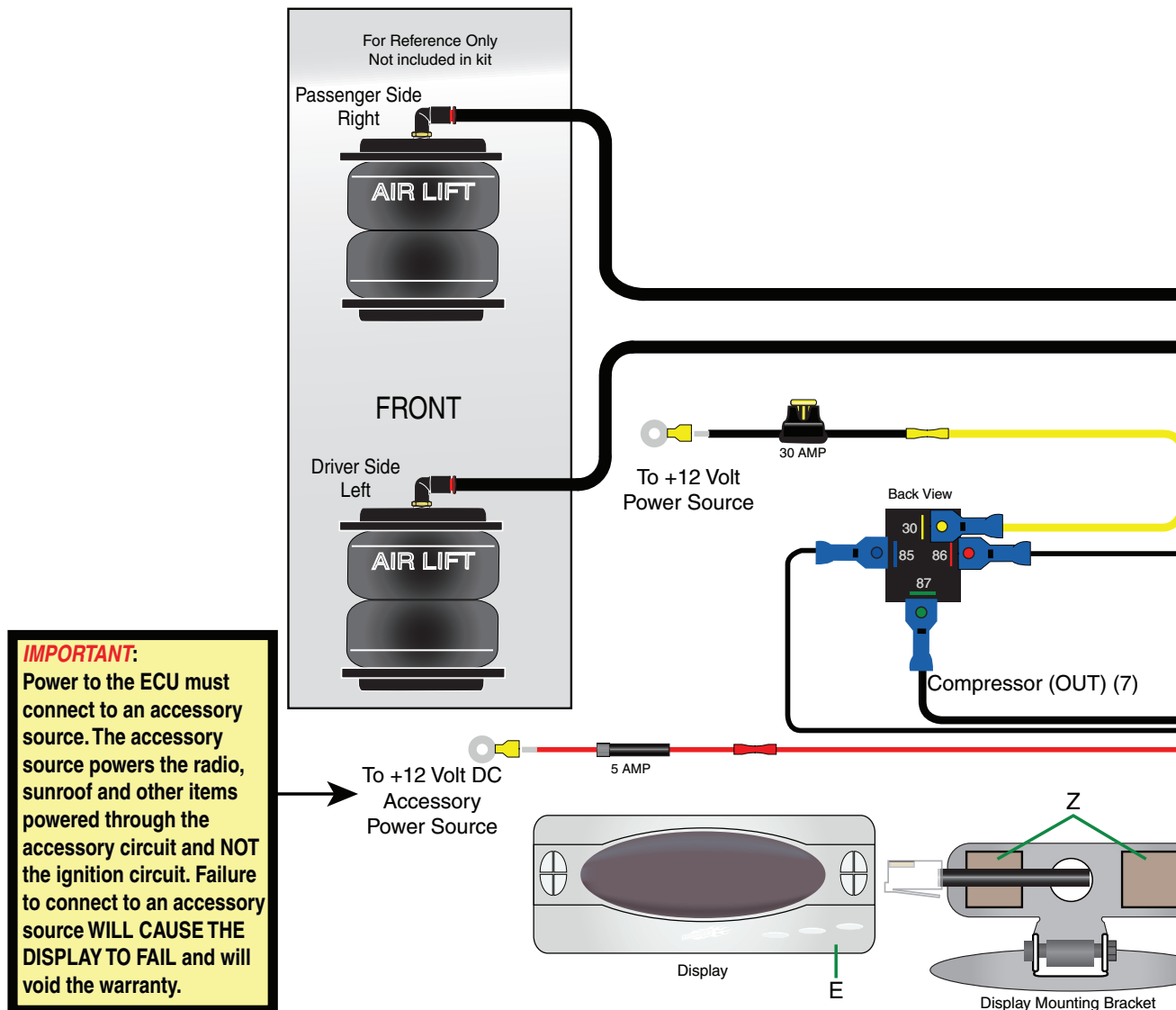
The display panel can be mounted by either placing the bracket on top of something or by attaching the bracket to hang below something (Figure 10).

2. Cut the velcro into 1" squares and attach two "hook" pieces of the velcro to the mounting bracket and attach the two corresponding "loop" pieces of the velcro to the back of the display panel (Fig. 17).



KIT DIAGRAM
HARDWARE LIST

Item	Part No.	Description	Quantity	Item	Part No.	Description	Quantity
A	16380	Compressor	1	O	21366	Inflation Valve	1
B	10991	5 Gallon Air Tank	1	P	21193	1/2" Hex Head Pipe Plug	2
C	17188	3/8" - 16 x 1.25" Bolt	4	Q	21370	1/2" MNPT x 1/2" Tube Elbow	2
D	20966	1/2" Air Line	40 ft.	R	10530	Air Line Cutter	1
E	27025	Digital Controller 175 psi	1	S	21637	3/8" MNPT x 1/2" Tube Elbow	6
or	27028	Digital Controller 145 psi	1	T	17132	Self-Tapping Screw	2
F	25033	Dig. Cntrl. ECU/Harness 175psi	1	U	23586	Thread Sealant	1
or	25034	Dig. Cntrl. ECU/Harness 145psi	1	V	17263	Self-Tapping Screw	10
G	25035	Manifold	2	W	18435	3/8" -16 Nyloc Nut	4
I	24001	Pressure Transducer/Sensor	1	X	18444	3/8" Flat Washer	8
J	26440	Display to ECU Line	1	Y	10415	Display Mounting Bracket	1
K	21247	1/2" MNPT x 1/4" FNPT Bushing	2	Z	10519	Velcro	1
L	21754	Drain Cock	1	AA	10422	Manifold Mounting Brackets	4
N	21251	1/2" MNPT x 1/8" FNPT Bushing	2	CC	17320	1/4" - 20 x 3/8" Screw	8



KIT DIAGRAM

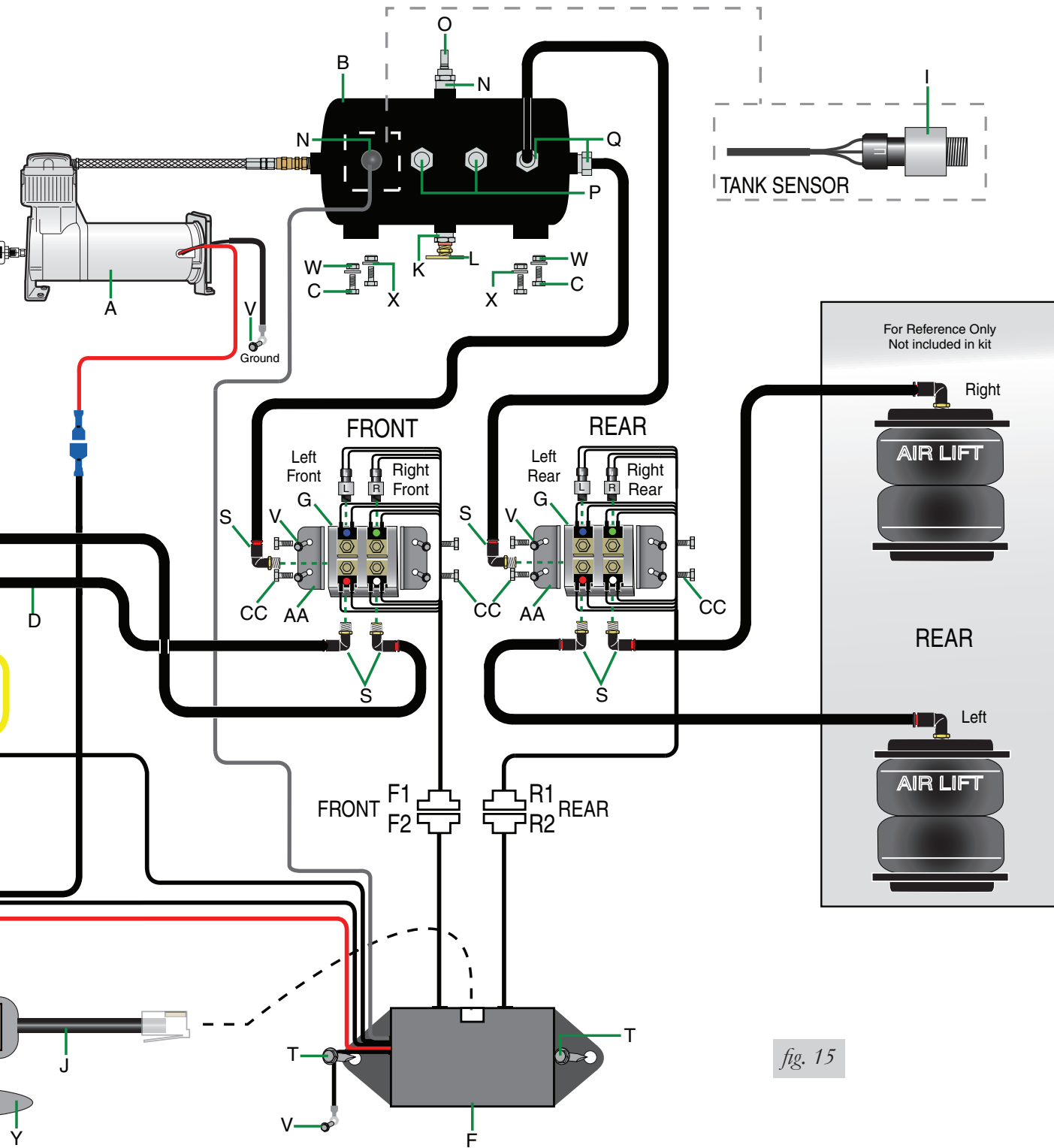


fig. 15

3. Stick the display unit to the mounting bracket.
4. Attach the mounting bracket to its mounting location in the same manner. Place three “hook” pieces of the velcro onto the bracket and place three “loop” pieces of the velcro onto the chosen mounting location (Fig. 17).
5. Stick the bracket to the mounting location.

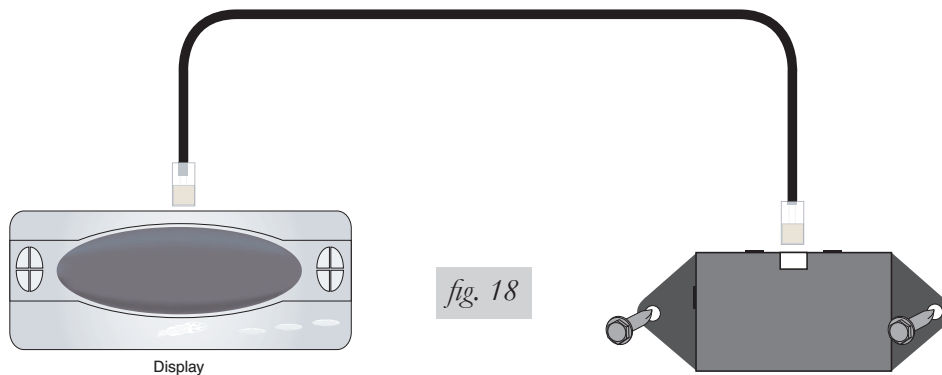
ATTACHING THE ECU AND DISPLAY PANEL

1. Choose a mounting location inside the cab of the vehicle for mounting the ECU.

NOTE

This can be under the dash panel.

2. Attach the bracket to the chosen mounting location using the provided screws (Fig. 18).
3. Attach the brackets to the display panel using the provided screws and attach the bracket to a chosen mounting location.
4. Tighten the ECU and display panel hardware.
5. Connect one end of the CAT 5 cable to the ECU and the other to the display panel (Fig. 18).

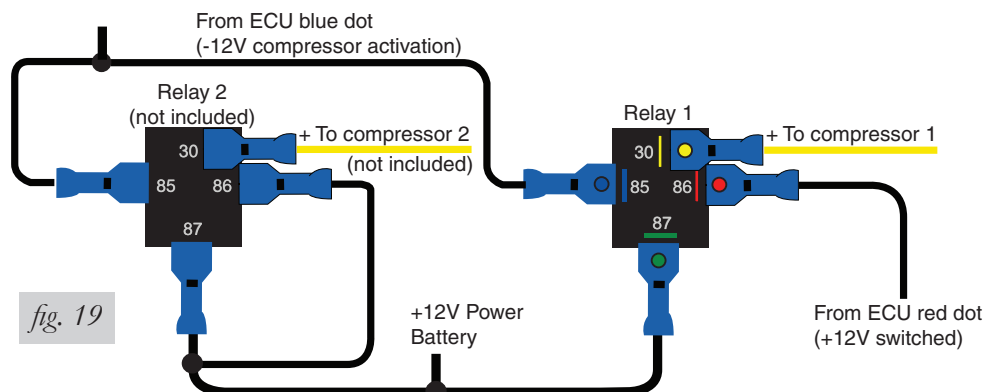


Troubleshooting

CHECKING THE SYSTEM

1. Inspect all air line connections with a solution of 1/5 dish soap to 4/5 water. Should a leak be detected in a push-lock-fitting, reinstall the air line to the fitting. Make sure air line is cut off squarely and that the air line is completely pushed into the fitting.
2. If the compressor or the solenoid fails to function, check the 20 AMP fuse and ground connection. Repair and replace as necessary.

TO ADD A SECOND COMPRESSOR



TROUBLESHOOTING GUIDE

Problem	Cause	Solution
<i>Compressor doesn't run.</i>	There is a blown fuse, bad ground, or poor electrical connections.	Replace the fuse, check the ground wire, or check the compressor connector.
<i>Solenoid doesn't work.</i>	There is a blown fuse or poor electrical connection.	Replace the fuse or check the solenoid connector.
<i>Compressor runs all the time.</i>	The compressor relay is defective or there is a leak.	Replace the relay or locate the leak and repair.
<i>Vehicle does not maintain ride height.</i>	The vehicle is overloaded.	Remove excess load from the vehicle.
<i>Nothing happens when the vehicle is started.</i>	There is a blown fuse or a poor connection.	Replace the fuses and check the electrical connections.
<i>The display does not light up.</i>	There is a blown fuse or a poor connection.	Replace the fuses and check the electrical connections.

Operational Instructions

THREE BASIC OPERATION MODES

Manual-Mode	The system displays the actual airbag pressures, and the user controls the pressure manually.
Auto-Mode	The system displays the pressure settings and automatically maintains the prescribed airbag pressures.
Option-Mode	The user can examine and change all option settings.

The system keeps the user's option settings in non-volatile memory so that they will be maintained each time the system is powered up. On power-up, the options settings are read and acted on appropriately.

SETTINGS

Ride Ht	The system will immediately restore the airbag pressures to the saved setting values on power-up.
Auto	When ride-height is selected (either through “Ride Ht” option setting or user selection during operation), the system will automatically maintain the airbag pressure at the current settings.
Leak	The system will display detected leaks in any of the airbag circuits. A leak is shown by the letter “L” next to the pressure reading.
Volts	The display will show the system voltage. If both “Volts” and “Tank” are enabled, the display will alternate between them every 20 seconds.
Tank	The display will show the current tank pressure. If both “Volts” and “Tank” are enabled, the display will alternate between them every 20 seconds.
Bright	Controls the display intensity. If the display intensity is changed while it is dimmed automatically by the vehicle lights connection, it will remain at the selected brightness until the next time the vehicle lights are turned on.
Seq	The system will perform pressure regulation on the airbags sequentially (left front, right front, left rear, right rear). If not enabled, the system will simultaneously adjust all airbag pressures.
Tune	To use the TUNE function, the tune option must be set to ON and it must be displayed when the ride height button is used to exit option-mode. The TUNE function will test the response of the system by exercising the airbags individually. The results are stored by the system for use in accurately controlling airbag pressures. The TUNE function must only be accomplished in a stationary vehicle on level ground.

If **Ride Ht** is enabled, the system will set the airbag pressures to the saved setting values on start-up. If **Auto** is enabled, the system will then enter auto-mode. If **Auto** is not enabled, the system will then go to manual-mode after the pressures are properly set.

USER INTERFACE

Front and rear button groups:

- These eight (8) buttons open the corresponding solenoid valve when pressed.
- In auto-mode, the system returns to the manual-mode if any of these buttons are pressed.
- In option-mode, the right-front buttons scroll through the options, while the left-rear buttons modify the displayed option’s value.

All-up/all-down buttons:

- Open all fill or dump solenoid valves when pressed.
- In auto-mode, the system returns to manual-mode if either of these buttons are pressed.

Ride-height button:

- The ride-height button has different functionality based on the length of time it is pressed.
- **Short Press** (less than 1 second)

- If in auto-mode, the system returns to manual-mode.
- If not in auto-mode, the system engages ride-height using the previously saved ride-height settings. If auto-pressure-regulation is enabled, the system enters auto-mode and maintains the airbag pressures automatically. If auto-pressure-regulation is not enabled, the system reverts to manual-mode after the airbag pressures are set. If the air tank pressure is too low (less than 135 psi), “Low Air” will be displayed and the system will remain in manual mode.
 - If any air bag pressure is at less than 30 psi, the system will initially attain pressures that are 10 psi greater than the ride height settings. The system will establish the desired ride height setting in approximately 15 seconds.
- **Medium Press** (between 1 and 3 seconds - “Set Ride Ht” is displayed)
 - If the system is in auto-mode, “Set Ride Ht” is not displayed and the system remains in auto-mode at the current settings.
 - If the system is not in auto-mode, it reads the current air bag pressures, saves these as the new settings, and then engages ride-height. If auto-pressure-regulation is enabled, the system enters auto-mode and maintains the air bag pressures automatically. If auto-pressure-regulation is not enabled, the system reverts to manual-mode after the air bag pressures are set.
- If the airbag pressures are outside the allowed range for ride height (30-120 psi) “Range” will be displayed and the system will not accept the new settings.
- **Long Press** (greater than 3 seconds - “Edit Options” is displayed)
 - The system enters option-mode to allow editing of the system options. Use the right-front buttons to select an option, the left rear buttons to change the option-setting.
 - Press the ride-height button to exit option editing and to return to the previous operating mode. If system was in auto-mode but “Auto” is now disabled, it returns to manual-mode.

Warranty and Returns Policy

Air Lift Company warrants its products, for the time periods listed below, to the original retail purchaser against manufacturing defects when used on catalog-listed applications on cars, vans, light trucks and motorhomes under normal operating conditions for as long as Air Lift manufactures the product. The warranty does not apply to products that have been improperly applied, improperly installed, used in racing or off-road applications, used for commercial purposes, or which have not been maintained in accordance with installation instructions furnished with all products. The consumer will be responsible for removing (labor charges) the defective product from the vehicle and returning it, transportation costs prepaid, to the dealer from which it was purchased or to Air Lift Company for verification.

Air Lift will repair or replace, at its option, defective products or components. A minimum \$10.00 shipping and handling charge will apply to all warranty claims. Before returning any defective product, you must call Air Lift at (800) 248-0892 in the U.S. and Canada (elsewhere, (517) 322-2144) for a Returned Materials Authorization (RMA) number. Returns to Air Lift can be sent to: Air Lift Company • 2727 Snow Road • Lansing, MI • 48917.

Product failures resulting from abnormal use or misuse are excluded from this warranty. The loss of use of the product, loss of time, inconvenience, commercial loss or consequential damages is not covered. The consumer is responsible for installation/reinstallation (labor charges) of the product. Air Lift Company reserves the right to change the design of any product without assuming any obligation to modify any product previously manufactured.

This warranty gives you specific legal rights and you may also have other rights that vary from state-to-state. Some states do not allow limitations on how long an implied warranty lasts or allow the exclusion or limitation of incidental or consequential damages. The above limitation or exclusion may not apply to you. There are no warranties, expressed or implied including any implied warranties of merchantability and fitness, which extend beyond this warranty period. There are no warranties that extend beyond the description on the face hereof. Seller disclaims the implied warranty of merchantability. (Dated proof of purchase required.)

Air Lift 1000.....	Lifetime Limited	LoadController/Dual.....	2 Year Limited
RideControl.....	Lifetime Limited	Load Controller (I).....	2 Year Limited
LoadLifter 5000*.....	Lifetime Limited	Load Controller (II).....	2 Year Limited
SlamAir.....	Lifetime Limited	SmartAir.....	2 Year Limited
AirCell.....	Lifetime Limited	Wireless AIR.....	2 Year Limited
Lifestyle & Performance**....	1 Year Limited	WirelessONE.....	2 Year Limited
LoadController/Single.....	2 Year Limited	Other Accessories.....	2 Year Limited

**formerly SuperDuty*
***formerly EasyStreet*

Replacement Information

If you need replacement parts, contact the local dealer or call Air Lift customer service at (800) 248-0892. Most parts are immediately available and can be shipped the same day.

Contact Air Lift Company customer service at (800) 248-0892 first if:

- Parts are missing from the kit.
- Need technical assistance on installation or operation.
- Broken or defective parts in the kit.
- Wrong parts in the kit.
- Have a warranty claim or question.

Contact the retailer where the kit was purchased:

- If it is necessary to return or exchange the kit for any reason.
- If there is a problem with shipping if shipped from the retailer.
- If there is a problem with the price.

Contact Information

If you have any questions, comments or need technical assistance contact our customer service department by calling (800) 248-0892, Monday through Friday, 8 a.m. to 7 p.m. Eastern Time. For calls from outside the USA or Canada, our local number is (517) 322-2144.

For inquiries by mail, our address is PO Box 80167, Lansing, MI 48908-0167. Our shipping address for returns is 2727 Snow Road, Lansing, MI 48917.

You may also contact us anytime by e-mail at sales@airliftcompany.com or on the web at www.airliftcompany.com.

Need Help?

Contact our customer service department by calling (800) 248-0892, Monday through Friday, 8 a.m. to 7 p.m. Eastern Time. For calls from outside the USA or Canada, our local number is (517) 322-2144.

**Register your warranty online at
www.airliftcompany.com/warranty**



Thank you for purchasing Air Lift products — the professional installer's choice!

Air Lift Company • 2727 Snow Road • Lansing, MI 48917 or PO Box 80167 • Lansing, MI 48908-0167
Toll Free (800) 248-0892 • Local (517) 322-2144 • Fax (517) 322-0240 • www.airliftcompany.com

Printed in
the USA