

# Heat Shield Installation

## P/N 34364

### I. Modifying The Exhaust For Clearance

1. Check the exhaust clearance and insure that it is 2"-3" from the air cylinder.
2. If necessary, loosen the clamps and move or rotate it to obtain additional clearance.

### II. Installing The Heat Shield

*CAUTION: The edges of the heat shield may be sharp. Wear protective gloves while bending and installing the heat shields.*

1. The heat shield will be installed on the exhaust pipe at the closest point to the air cylinder to protect the cylinder from the radiant heat of the exhaust system.
2. Attach radiator clamps loosely around the exhaust pipe nearest to the air cylinder.
3. Bend the heat shield tab out at a 90° angle and again half the distance up at a 90° angle to form an "L" shape. Repeat on the other tab (Inset A).
4. Position the heat shield and insert the heat shield tabs beneath the two radiator clamps. Tighten the clamps (Figure 2).

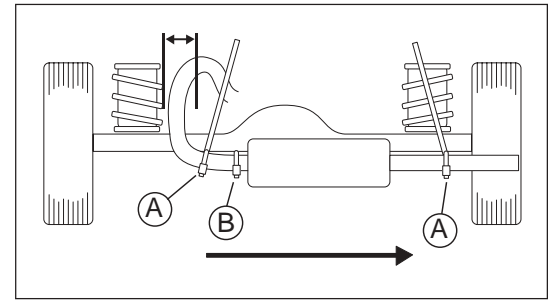

Figure 1

# Heat Shield Installation

## P/N 34364

### I. Modifying The Exhaust For Clearance

1. Check the exhaust clearance and insure that it is 2"-3" from the air cylinder.
2. If necessary, loosen the clamps and move or rotate it to obtain additional clearance.

### II. Installing The Heat Shield

*CAUTION: The edges of the heat shield may be sharp. Wear protective gloves while bending and installing the heat shields.*

1. The heat shield will be installed on the exhaust pipe at the closest point to the air cylinder to protect the cylinder from the radiant heat of the exhaust system.
2. Attach radiator clamps loosely around the exhaust pipe nearest to the air cylinder.
3. Bend the heat shield tab out at a 90° angle and again half the distance up at a 90° angle to form an "L" shape. Repeat on the other tab (Inset A).
4. Position the heat shield and insert the heat shield tabs beneath the two radiator clamps. Tighten the clamps (Figure 2).

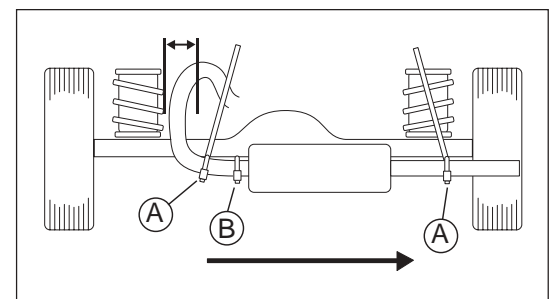

Figure 1

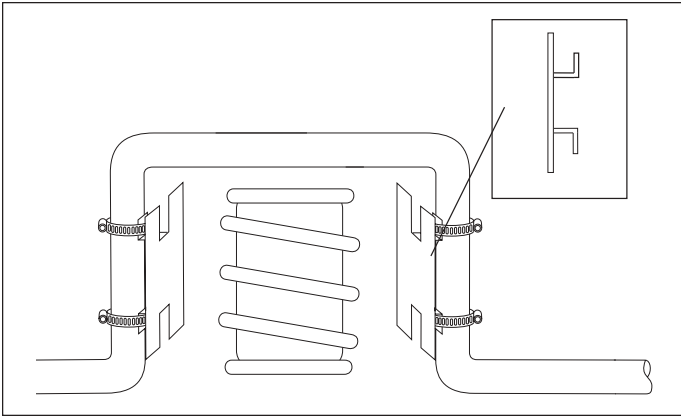

Figure 2

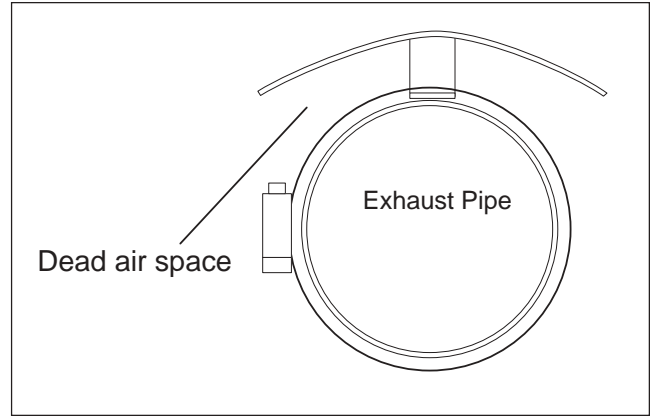

Figure 3

5. Bend the heat shield to form it around the tail pipe. Be sure to maintain a dead air space of 1/2"-1" between the tail pipe and the heat shield (Figure 3).
6. Repeat procedure for the remaining heat shield.

**Thank you for purchasing Air Lift Products**

Mailing Address: AIR LIFT COMPANY; P.O. Box 80167; Lansing, MI 48908-0167  
 Street Address: AIR LIFT COMPANY; 2710 Snow Rd.; Lansing, MI 48917  
 Phone: (517) 322-2144 Fax: (517) 322-0240  
[www.airliftcompany.com](http://www.airliftcompany.com)



**For Technical Assistance call 1-800-248-0892**

Printed in the USA

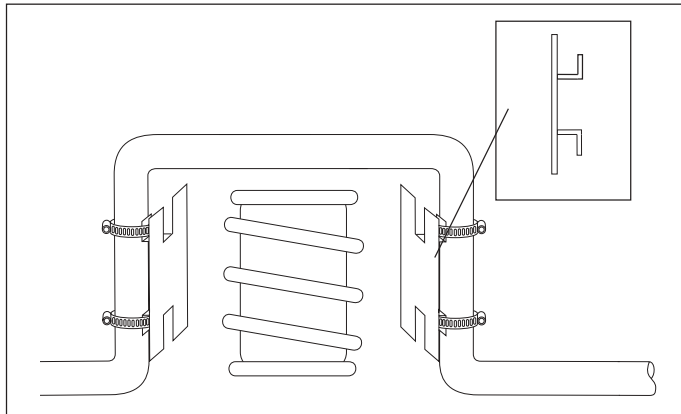

Figure 2

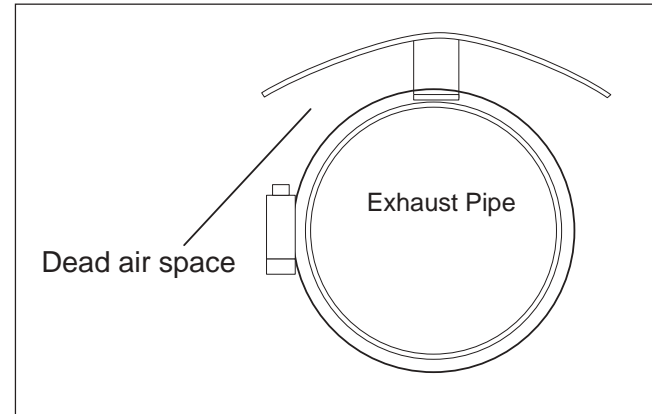

Figure 3

5. Bend the heat shield to form it around the tail pipe. Be sure to maintain a dead air space of 1/2"-1" between the tail pipe and the heat shield (Figure 3).
6. Repeat procedure for the remaining heat shield.

**Thank you for purchasing Air Lift Products**

Mailing Address: AIR LIFT COMPANY; P.O. Box 80167; Lansing, MI 48908-0167  
 Street Address: AIR LIFT COMPANY; 2710 Snow Rd.; Lansing, MI 48917  
 Phone: (517) 322-2144 Fax: (517) 322-0240  
[www.airliftcompany.com](http://www.airliftcompany.com)



**For Technical Assistance call 1-800-248-0892**

Printed in the USA